



IGNITION TRANSFORMERS



50 years of never ending innovation





We start the flame



INDEX

Company		page	4
Technology		page	5
Electronic Transformers	Characteristics, outlets, inlets	page	6
Inductive Transformers	Characteristics, outlets, inlets	page	7
Electronic Transformers	The applications	page	8
Inductive Transformers	The applications	page	10
TRK_{VD}		page	12
TRK_{HK}		page	14
TRK_{HD}		page	16
TRJ		page	17
TRJ 3		page	18
TRM		page	19
TRL		page	20
TRH		page	21
TRW1		page	22
TRW2		page	23
TRUP		page	24
TRXXPX-ISO		page	25
TRE		page	26
TRS		page	28
TRG		page	30
TRZ		page	32
Accessories		page	33

COMPANY



4



COFI, since 1974

The company was founded in 1974 with the aim of applying an innovative technology in the production of transformers for the ignition of gas burners and diesel. The application of this technology has revolutionized traditional production techniques for the isolation of high voltages, improving the electrical properties and durability, increasing the mechanical properties and while reducing the environmental impact of the materials used in the isolation.

The company has grown steadily investing in the search for solutions, materials and equipment.

Technology

The technology applied to the construction of high-voltage insulation of the highest quality, is the driving force behind the company and represents a breakthrough in this area. The high insulation is obtained by a combined system of encapsulating low pressure of thermosetting epoxy resin and the use of technology to polyester film in the insulation of the coils.

The benefits of this innovative combination are manifold:

- Mechanical properties and excellent aesthetic
- Electrical properties of unquestionable superiority
- Resistance to high temperatures superior to other materials traditionally applied
- Heat dissipation extremely effective
- Excellent resistance to chemicals and fuel oils
- Elimination of harmful materials



from the manufacturing process resulting in volatile reducing environmental impact.

This production process has shown its validity technology both conceptually and in practice, with millions of applications, used for many years by leading manufacturers internationally recognized.

The policy of the company throughout its history has always been directed towards the achievement of total quality is constructive and aesthetic, paying particular attention to the supply of top quality materials and following the technological changes constantly.

R&D

COFI has always invested heavily in research and development, while continuing to improve existing products and to find new solutions to the increasingly demanding market. In recent years COFI products range has been able to benefit from this ongoing research with the release of several new and innovative products in the field of ignitions, making only the width of the range in this area. COFI is also able to provide a customized product for any need, our technical department is available to test the feasibility and to perform sampling of non-standard specifications. COFI constructs in series ionizers transformers, demagnetizers, voltage doublers, equipment for fencing and other areas that do not belong to the world of ignitions where the construction of the transformer is sometimes considerably distant from the standard. COFI also works on the development of sensors and transducers that produce using her technology.

COFI is also active in the field of fuel cells with important research projects in the field of renewable energy in collaboration with important Italian and foreign universities.

Service

The optimal application of the high-voltage requires a careful study of the accessories to guarantee a certainty of ignition performance, therefore the maximum attention is dedicated to the study of functions of the cables and connections of the protections of the outputs of high tension, with the realization of parts that integrate various solutions in a single cable, eliminating assembly difficulties and uncertainties of operation.

The company also takes great care of the special needs of the customer, realizing also accessories specification, studying the effectiveness and optimization. Relevant in this regard is the EMC measures laboratory with the latest generation of equipments for performing measurements of electromagnetic compatibility according to EN55014 standards, and the subsequent study of the details necessary to make compatible the installation of the transformer. Most of the products are certified by the most representative organizations in Europe such as VDE and IMQ, as well as UL and CSA for the American market.

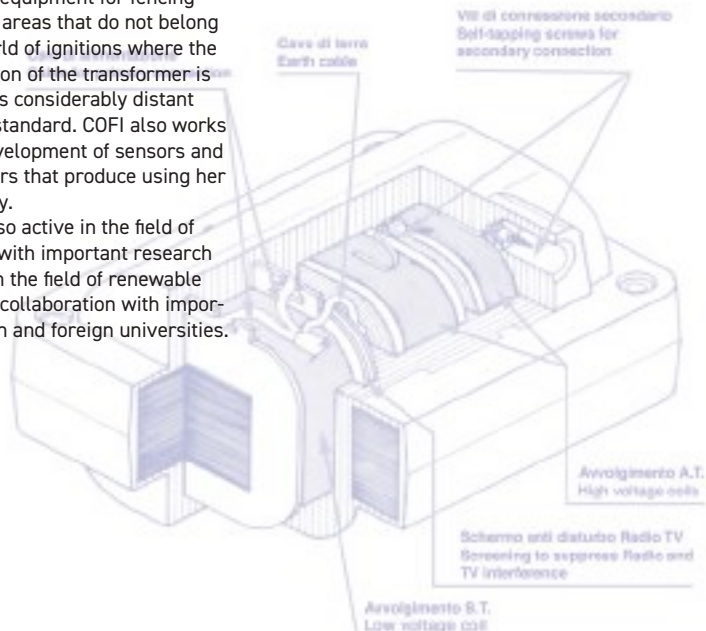



A COMPANY DRIVEN BY TECHNOLOGY

Construction of high-voltage transformers

The COFI transformers are manufactured with top-quality choice materials in accordance with CEI EN 61558-2-3. The copper wire used for the secondary circuit winding is H 180°C class, while the wire for the primary circuit winding is H 200°C class. The insulation between layers in the high-voltage coils is ensured by a polyester film with high dielectric constant. The transformer is then encapsulated with a thermosetting epoxy resin resistant to a temperature of over 180°C, that offers it high mechanical resistance together with excellent dielectric properties, resistance to fuel oils and to chemical agents, very good thermal dissipation and - last but not least - elimination of harmful volatile materials from the production cycle. Moreover, the materials enable a surface finish that is comparable with metal. All the other components have been chosen from the best available on the market, taking into account the best resistance to temperature in order to ensure indestructibility even in the most severe duty conditions.

Encapsulation

The company has developed over the years different systems of encapsulation with epoxy resins, to obtain the maximum level of insulation of different applications, always taking advantage of the best available technology on the

market. In inductive transformers are used thermosetting epoxy resins to transfer injection, now widely used in the automotive industry. Electronic transformers are potted with epoxy resin under a very high vacuum. The line, fully automated, guarantees a constant quality on a large scale. Both systems offer exceptional performance and longevity of the product. The company is as always at the forefront in the isolation of high voltages and in production technologies.

Operation cycles

The transformer can operate, depending on the type, on continuous or intermittent duty in accordance with the technology applied to the burner and the control device. The transformers at intermittent duty can work at different inserting time, depending on the type: ED=25% on 4' means that the transformer can be switched ON for 1 min. and then shall be OFF for at list 3 min. Total cycle time is 4 min. So ED=33% on 3' means that the transformer work 1 min. ON and 2 min. OFF. ED=100% means that the transformers can operate continuously. The electronic transformers are designed to work with ambient temperatures up to 60°C, the inductive one at 35°C.

Electromagnetic Compatibility (EMC)

CE marking made it mandatory for all manufacturers of consumer and industrial machines to comply

with the European directives on low voltage 2014/35/EU and on electromagnetic compatibility 2014/30/EU. The discharge from the burner causes electromagnetic disturbance, both conducted and radiated. The disturbance propagates differently according to the set-up of the machines electric connections or for instance the different opening of the terminals or the different positioning of the transformer in the machine. COFI laboratory found a general solution to help the users of transformers to not exceed the curves provided in the CEI ED 55014-1 standards.

Final testing

All COFI transformers undergo strict final testing before being packed in order to ensure trouble-free operation and almost unlimited durability for the transformers that pass the test.

Customized supply

In some applications, the input values (foreign countries) and the output values of the standard transformer as shown in our catalogue must be changed. The personnel in our technical department checks if this can be done, and produces samples with non-standard features. We mass-produce transformers for ionizers, demagnetizers, voltage doublers, devices for fencing, and other fields apart from ignition devices, where the transformer often requires special features. We also develop sensors and transducers, which we manufacture, with our technology.

* Available certifications



* The indicated certifications are available on some models depending on the target market and the type of product, and are indicated in the product tables for each series. On request, it can be extended to models not currently approved. All products are still designed and built according to the standards IEC.

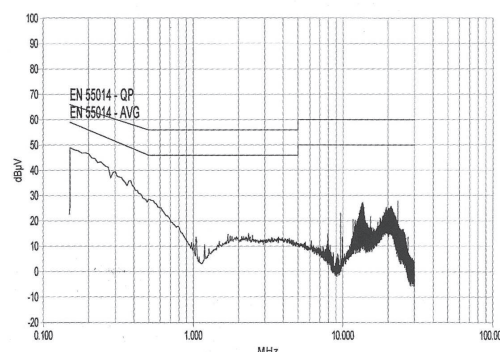
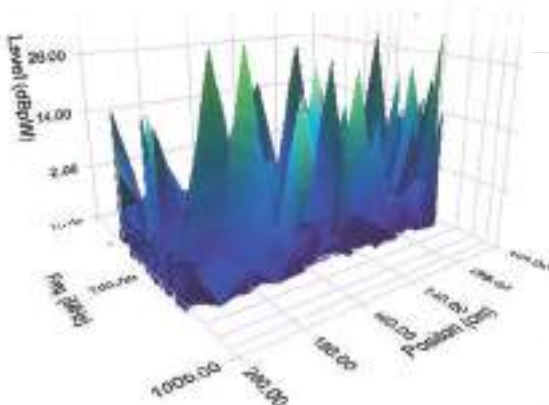

ELECTRONIC TRANSFORMERS



6



Series of transformers designed with the electronic technology able to produce a discharge of high potential in high frequency (10-20kHz). There are several electronic configurations, from simple and more economical one, to the most sophisticated versions of high power and continuous operation with temperature and current control, for gas applications (1 pole) and oil application (2 poles). The power supply voltages ranging is from 100 Vac to 400 Vac, 12 and 24 Vdc. Thanks to the complete potting of transformer with premium resins, our electronic products enable safe operation even in extreme environmental conditions, from -20 °C to + 60

°C and on some models it is allowed to use it at also - 40 °C or + 90 °C. Numerous configurations, with inputs / outputs and dimensions, are available to meet international standards, making available a range of products suitable for any installation. The company also manufactures products tailored to the specific customer applications. All products are filtered internally against electromagnetic disturbances. The range of products suitable for use in the US market is approved (UL Recognized Component), while models for the European market are IMQ approved according to the product standard for burners EN 61558-2-3.

Serie TRK	Standard
Serie TRJ	Best Price
Serie TRH	High power
Serie TRL 12 e 24 Vdc	High power
Serie TRM 24 Vdc	Middle power
Serie TRW	Condensing Boilers
Serie TRJ3	Smart igniter
The power of an intermittent transformer that adapt itself at an eventual continuous duty.	

Applications

The electronic ignition transformer is suitable to be applied to all kind of oil and gas burners, wall hang boilers, hot water high pressure cleaners and anti-mosquito equipment. These applications are indicated by a symbol beside each type of product as follows.

Oil Burners		Gas Burners		Hot water high pressure cleaners	
-------------	---	-------------	---	----------------------------------	--

Inlets | Ingressi

Plug D		Plug K	
--------	---	--------	---

Outlets





H plug, Horizontal output plug, Ø 4mm		V plug, Vertical output plug, Ø 4mm (13.5 mm deep)	
---------------------------------------	---	--	---

Transformer code system on last page (35)

INDUCTIVE TRANSFORMERS

Applications

The inductive ignition transformer is suitable to be applied to all kind of oil and gas burners, hot water high pressure cleaners and anti-mosquito equipment. These applications are indicated by a symbol beside each type of product as follows. 50/60Hz operations allow to use the transformers also with very long cable.

Oil Burners		Gas Burners	
Hot water high pressure cleaners		Anti-mosquito equipment	

Classic wound transformer with ferromagnetic core, covered with thermosetting epoxy resin which gives it a metallic appearance and at the same time highly insulating. Produced for over 40 years in over 10 million pieces, are designed for ignition applications at 360°, from gas and oil burners to the high-pressure washers machines and anti-mosquito equipment, in addition to high-voltage and ozone generators. They are available in 4 product families depending on the power from the smaller Z, the small E, the standard S, up to the great power G. The principle of operation at 50 or 60 Hz makes it suitable for applications where the cables length are longer than 2m. Available in several versions of inlets and outlets combined with input voltages and output currents fully customizable.





Inlets

These icons represent all the different kind of primary connection for each product

Standard buried cable L=380mm		COFI plug		Triangle plug	
-------------------------------	---	-----------	---	---------------	---

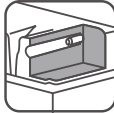
Outlets

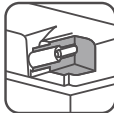

These icons represent all the different kind of high voltage connections for each product

Code SP, plug, Ø 4 (21.5 mm deep) eccentric hole		Code SPPRO, hole Ø 6, plug Ø 4 for cable Ø 5.2 (35 mm deep)	
Code VIMAN, self-tapping screw with sleeve (25 mm deep)		Code SPMAN, plug Ø 4 with sleeve (23 mm deep)	
Code SPRAS, flush plug, Ø 4 (13.5 mm deep)		Code VIRAS, flush self-tapping screw (18 mm deep)	

ELECTRONIC TRANSFORMERS



8

Series	Type	Vin	Iout cc mA	ED	Output	Applications			page
									

TRK ELECTRONIC TRANSFORMERS



TRK1-20CVD	220-240V	20	100%	Grounded center		•	•	12
TRK1-20PCVD	220-240V	20	100%	Grounded pole	•		•	13
TRK1-30CVD	220-240V	30	100%	Grounded center		•	•	12
TRK1-30CHD	220-240V	30	100%	Grounded center		•	•	16
TRK1-30PCVD	220-240V	30	100%	Grounded pole	•		•	13
TRK2-35	220-240V	35	33% on 3'	Grounded center		•		12
TRK2-30PVD	220-240V	30	33% on 3'	Grounded pole	•			13
TRK2-30PFVD	220-240V	30	33% on 3'	Grounded pole	•			13
TRK2-30PVDUS	220-240V	30	33% on 3'	Grounded pole	•			13
TRK2-30PFVDUS	220-240V	30	33% on 3'	Grounded pole	•			13
TRK2-30PHD	220-240V	30	33% on 3'	Grounded pole	•			16
TRK2-40VD	220-240V	40	33% on 3'	Grounded center		•		12
TRK2-40HD	220-240V	40	33% on 3'	Grounded center		•		16
TRK2-40HK	220-240V	40	33% on 3'	Grounded center		•		14
TRK2-40HKL	220-240V	40	33% on 3'	Grounded center		•		14
TRK2-40PVD	220-240V	40	33% on 3'	Grounded pole	•			13
TRK2-40PHK	220-240V	40	33% on 3'	Grounded pole	•			15
TRK2-40PHKL	220-240V	40	33% on 3'	Grounded pole	•			15
TRK2-40SHK	220-240V	40	33% on 3'	Insulated		•		14
TRK2-40SVD	220-240V	40	33% on 3'	Insulated		•		12
TRK2-40PHD	220-240V	40	33% on 3'	Grounded center		•		16
TRK1-20CUVD	120V	20	100%	Grounded center		•		12
TRK1-20PCUVD	120V	20	100%	Grounded pole	•			13
TRK2-30PUVD	120V	26	33% on 3'	Grounded pole	•			13
TRK2-30PUFVD	120V	26	33% on 3'	Grounded pole	•			13
TRK2-30UVD	120V	30	33% on 3'	Grounded center		•		12

TRJ ELECTRONIC TRANSFORMER





TRJ2-30VD	220-240V	21	33% su 3'	Grounded center		•		17
TRJ2-30PVD	220-240V	20	33% su 3'	Grounded pole	•			17
TRJ3-40CVD	220-240V	30	100%	Grounded center		•	•	18



Series	Type	Vin	Energy /Iout cc [mJ]	ED	Output	Applications	page
--------	------	-----	----------------------	----	--------	--------------	------



TRW CAPACITANCE DISCHARGE IGNITER

	TRW1P2E	220-240V	20 mJ	100%	Grounded center	•			22
	TRW1P2ER	220-240V	20 mJ	100%	Grounded center	•			22
	TRW1P4E	220-240V	20 mJ	100%	Grounded center	•			22
	TRW1P4ER	220-240V	20 mJ	100%	Grounded pole	•			22
	TRW1S2M1	220-240V	20 mJ	100%	Insulated	•			22
	TRW1S4E	220-240V	20 mJ	100%	Insulated	•			22
	TRW2P4M	220-240V	20 mJ	100%	Grounded center	•			23
	TRW2P4ER	220-240V	20 mJ	100%	Grounded pole	•			23

TRM ELECTRONIC TRANSFORMER

	TRM24-20PC	24 Vdc	14	100%	Grounded pole	•	•	•	19
---	------------	--------	-----------	------	---------------	---	---	---	----

TRL POWER ELECTRONIC TRANSFORMERS

	TRL12-30C	12 Vdc	22	100%	Grounded center		•	•	20
	TRL24-30C	24 Vdc	22	100%	Grounded center		•	•	20
	TRL12-30PC	12 Vdc	22	100%	Grounded pole	•		•	20
	TRL24-30PC	24 Vdc	22	100%	Grounded pole	•		•	20

TRH POWER ELECTRONIC TRANSFORMERS

	TRH2-30CU	120V	30	100%	Grounded center		•	•	21
	TRH2-30C	230V	30	100%	Grounded center		•	•	21
	TRH2-30CQ	400V	30	100%	Grounded center		•	•	21
	TRH2-60	230V	40	33% on 3'	Grounded center		•		21
	TRH2-40U	120V	50	33% on 3'	Grounded center		•		21

TRUP TOP MOUNTED IGNITION TRANSFORMER

	TRUP25-30C	220-240V	30	100%	Grounded center				24
---	------------	----------	-----------	------	-----------------	--	--	--	----

INDUCTIVE TRANSFORMERS



10

Series	Type	Vin	Vout [kV]	Iout cc [mA]	ED	Output	Applications				page

TRZ INDUCTIVE TRANSFORMER



TRZ410CL	230V	2x2	10	100%	Grounded center				•		32
TRZ510C	230V	2x2,5	10	100%	Grounded center				•		32
TRZ4.509PC	230V	1x4,5	9	100%	Grounded pole				•		32

TRE INDUCTIVE TRANSFORMER





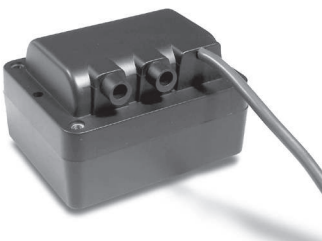

TRE308C	230V	2x1,5	8	100%	Grounded center				•		26
TRE510C	230V	2x2,5	10	100%	Grounded center				•		26
TRE820	230V	2x4	20	19% on 3'	Grounded center	•	•				26
TRE210PC	230V	1x2	10	100%	Grounded pole				•		25
TRE410PC	230V	1x4	10	100%	Grounded pole	•					25
TRE510PC	230V	1x5	10	100%	Grounded pole	•					25
TRE820P	230V	1x8	20	19% on 3'	Grounded pole	•					25
TRE820PISO	230V	1x8	20	19% on 3'	Insulated	•					25

TRG INDUCTIVE TRANSFORMER



TRG1015C	230V	2x5	15	100%	Grounded center		•			•	30
TRG1020C	230V	2x5	20	100%	Grounded center		•			•	30
TRG1035	230V	2x5	35	25% on 4'	Grounded center		•			•	30
TRG1035 US	120V	2x5	35	25% on 4'	Grounded center		•				30
TRG1225	230V	2x6	25	25% on 4'	Grounded center		•				30
TRG1230	230V	2x6	30	33% on 3'	Grounded center		•				30
TRG1230	120V	2x6	30	25% on 4'	Grounded center		•				30
TRG623PC US	120V	1x6	23	100%	Grounded pole	•					31
TRG820PC	230V	1x8	20	100%	Grounded pole	•					31
TRG835P	230V	1x8	35	25% on 4'	Grounded pole	•					31
TRG1020PC	230V	1x10	20	100%	Grounded pole	•					31
TRG1035P	230V	1x10	35	25% on 4'	Grounded pole	•					31



Series	Type	Vin	Vout [kV]	Iout cc [mA]	ED	Output	Applications	page
							   	

TRS INDUCTIVE TRANSFORMER



TRS513C	230V	2x2,5	10	100%	Grounded center			•	•	28
TRS812C	230V	2x4	12	100%	Grounded center		•		•	28
TRS815C	230V	2x4	15	100%	Grounded center				•	28
TRS818C	230V	2x4	18	100%	Grounded center		•		•	28
TRS820	230V	2x4	20	25% on 4'	Grounded center		•			28
TRS1020	230V	2x5	20	25% on 4'	Grounded center		•			28
TRS1020	230V	2x5	20	33% on 3'	Grounded center		•		•	28
TRS1030	230V	2x5	30	25% on 4'	Grounded center		•			28
TRS1220	230V	2x6	20	25% on 4'	Grounded center		•			28
TRS404PC	230V	1x4	4	100%	Grounded pole	•	•			29
TRS505PC	230V	1x5	5	100%	Grounded pole	•	•			29
TRS508PC	230V	1x5	8	100%	Grounded pole	•	•			29
TRS510PC	230V	1x5	10	100%	Grounded pole	•	•			29
TRS515PC	230V	1x5	15	100%	Grounded pole	•	•			29
TRS6.508PC	230V	1x6,5	8	100%	Grounded pole	•	•			29
TRS606PC	230V	1x6,5	6	100%	Grounded pole	•	•			29
TRS610PC	230V	1x6,5	10	100%	Grounded pole	•	•			29
TRS708PC	230V	1x7	8	100%	Grounded pole	•	•			29
TRS818PC	230V	1x8	18	100%	Grounded pole	•	•			29
TRS820P	230V	1x8	20	25% on 4'	Grounded pole	•	•			29
TRS723P US	120V	1x7	23	25% on 4'	Grounded pole	•	•			29
TRS820PISO	230V	1x8	20	33% on 3'	Insulated	•	•			29
TRS830P	230V	1x8	30	25% on 4'	Grounded pole	•	•			29
TRS1815C/IS	230V	1x2	15	100%	Insulated	•	•			29

TRK_{VD}

Vertical outlet | Plug D



12

2 POLES



Technical drawing [mm]

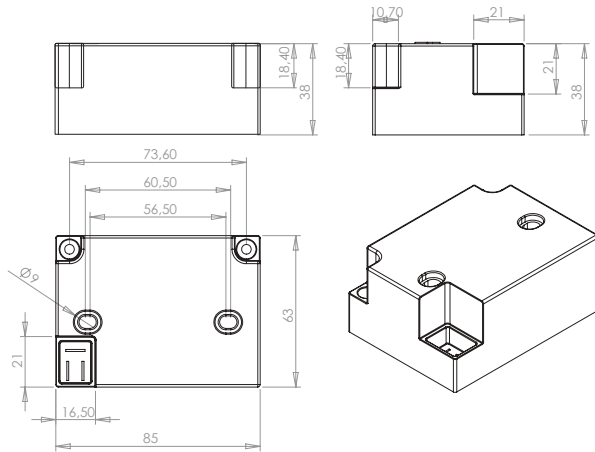

Inlet

Plug D

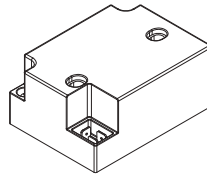

Outlet

V plug, vertical output plug, Ø 4mm

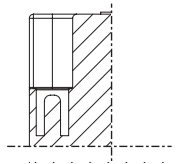

Type	Vin	Pin	Iout cc	Iout burn*	Vout	ED	Ta	Output	Note
CONTINUOUS 100%									
TRK1-20CVD	220-240V	30W	20 mA	12 mA	2x14 kV	100%	60°C	Grounded center	CE
TRK1-30CVD	230V	30W	30 mA	17 mA	2x12 kV	100%	60°C	Grounded center	UL CE
TRK1-20CUVD	120V	22W	20 mA	12 mA	2x14 kV	100%	60°C	Grounded center	cRU US
INTERMITTENT									
TRK2-35	220-240V	65W	35 mA	20 mA	2x12 kV	33% on 3'	60°C	Grounded center	CE
TRK2-40VD	220-240V	65W	40 mA	24 mA	2x10 kV	33% on 3'	60°C	Grounded center	UL CE
TRK2-40SVD**	220-240V	65W	40 mA	24 mA	15 kV	33% on 3'	60°C	Insulated	
TRK2-30UVD	120V	60W	30 mA	20 mA	2x12 kV	33% on 3'	60°C	Grounded center	cRU US

*Current measured on the burner with 5mm spark gap, blowing air and suppressed cables.

**One pole shall be grounded.

Applications



Available certification



Transformers of widely used standards, produced in many different versions, with different powers and suitable for all applications on the market inputs and outputs configurations. Available in intermittent and continuous version for gas and oil applications, it is available filtered or unfiltered (F).

STANDARD



1 POLE

13

Technical drawing [mm]

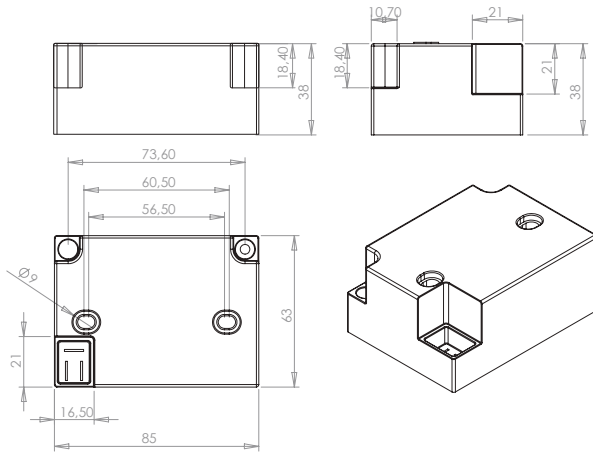

Inlet

Plug D

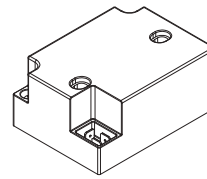

Outlet

V plug, vertical output plug, Ø 4mm

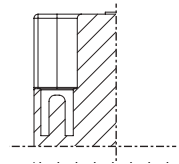

Type	Vin	Pin	Iout cc	Iout burn*	Vout	ED	Ta	Output	Note
CONTINUOUS 100%									
TRK1-20PCVD	220-240V	30W	20 mA	12 mA	1x15 kV	100%	60°C	Grounded pole	CE
TRK1-30PCVD	220-240V	30W	30 mA	17 mA	1x15 kV	100%	60°C	Grounded pole	CE
TRK1-20PCUVD	120V	30W	20 mA	12 mA	1x15 kV	100%	60°C	Grounded pole	CE
INTERMITTENT									
TRK2-30PVD	220-240V	63W	30 mA	20 mA	1x15 kV	33% on 3'	60°C	Grounded pole	Y CE
TRK2-30PFVD	220-240V	63W	30 mA	20 mA	1x15 kV	33% on 3'	60°C	Grounded pole	CE
TRK2-30PVDUS	230V	69W	30 mA	20 mA	1x15 kV	33% on 3'	60°C	Grounded pole	C RU US
TRK2-30PFVDUS	230V	69W	30 mA	20 mA	1x15 kV	33% on 3'	60°C	Grounded pole	C RU US
TRK2-40PVD	220-240V	65W	40 mA	24 mA	1x15 kV	33% on 3'	60°C	Grounded pole	Y CE
TRK2-30PUVD	120V	60W	36 mA	20 mA	1x15 kV	33% on 3'	60°C	Grounded pole	C RU US
TRK2-30PUFVD	120V	60W	36 mA	20 mA	1x15 kV	33% on 3'	60°C	Grounded pole	C RU US

*Current measured on the burner with 5mm spark gap, blowing air and suppressed cables.

Applications



Available certification



TRK HK

Horizontal outlet | Plug K



14

2 POLES



Technical drawing [mm]

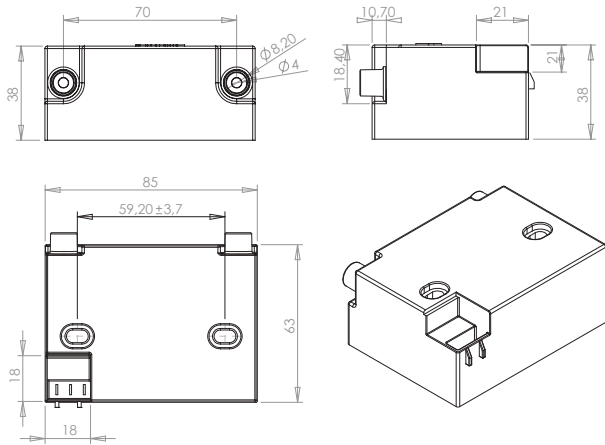

Inlet

Plug K

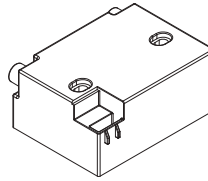

Plug K with grand plate L

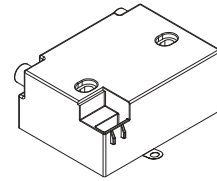

Outlet

H plug, horizontal output plug, \varnothing 4mm (13.5 mm deep)

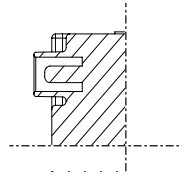

Type	Vin	Pin	Iout cc	Iout burn*	Vout	ED	Ta	Output	Note
INTERMITTENT									
TRK2-40HK	220-240V	65W	40 mA	24 mA	2x10 kV	33% on 3'	60°C	Grounded center	
TRK2-40HKL	220-240V	65W	40 mA	24 mA	2x10 kV	33% on 3'	60°C	Grounded center	
TRK2-40SHK**	220-240V	65W	40 mA	24 mA	15 kV	33% on 3'	60°C	Insulated	

*Current measured on the burner with 5mm spark gap, blowing air and suppressed cables.
 **One pole shall be grounded.

Applications



Available certification



Transformers of widely used standards, produced in many different versions, with different powers and suitable for all applications on the market inputs and outputs configurations. Available in intermittent and continuous version for gas and oil applications.

STANDARD

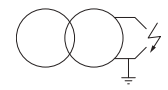

1 POLE

Technical drawing [mm]

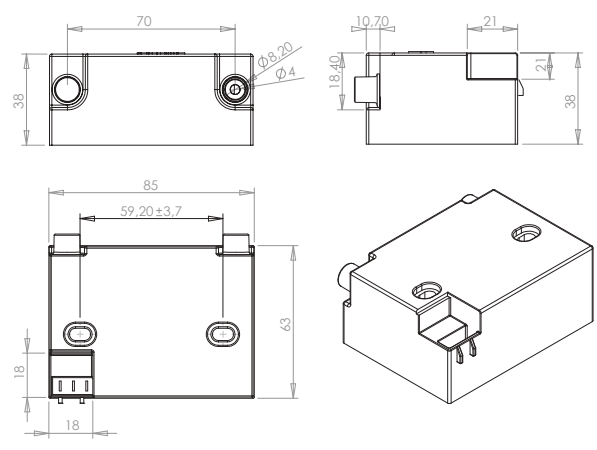

Inlet

Plug K

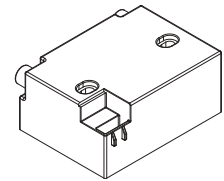

Plug K with grand plate L

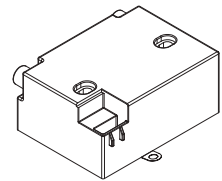

Outlet

H plug, horizontal output plug, Ø 4mm (13.5 mm deep)

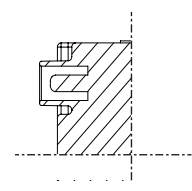

Type	Vin	Pin	Iout cc	Iout burn*	Vout	ED	Ta	Output	Note
INTERMITTENT									
TRK2-40PHK	220-240V	65W	40 mA	24 mA	1x15 kV	33% on 3'	60°C	Grounded pole	
TRK2-40PHKL	220-240V	65W	40 mA	24 mA	1x15 kV	33% on 3'	60°C	Grounded pole	

*Current measured on the burner with 5mm spark gap, blowing air and suppressed cables.

Applications



Available certification



TRK HD

Horizontal outlet | Plug D



2 POLES

16



Technical drawing [mm]

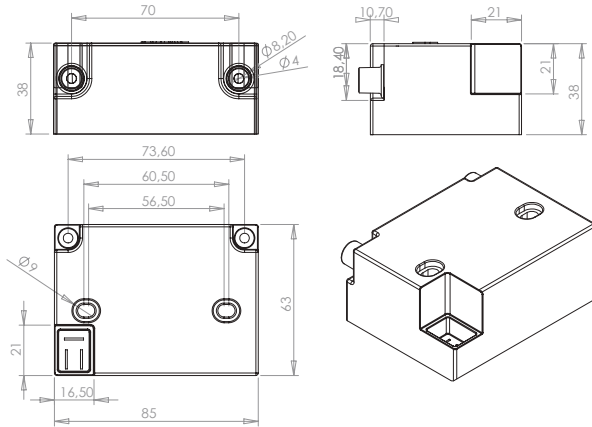

Inlet

Plug D

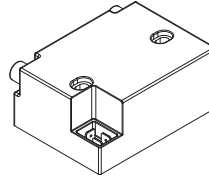

Outlet

H plug, horizontal output plug, \varnothing 4mm (13.5 mm deep)

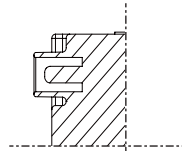

STANDARD

Type	Vin	Pin	Iout cc	Iout burn*	Vout	ED	Ta	Output	Note
CONTINUOUS 100%									
TRK1-30CHD	220-240V	30W	30 mA	17 mA	2x12 kV	100%	60°C	Grounded center	
INTERMITTENT									
TRK2-40HD	220-240V	65W	40 mA	24 mA	2x10 kV	33% on 3'	60°C	Grounded center	

*Current measured on the burner with 5mm spark gap, blowing air and suppressed cables.

1 POLE



Technical drawing [mm]

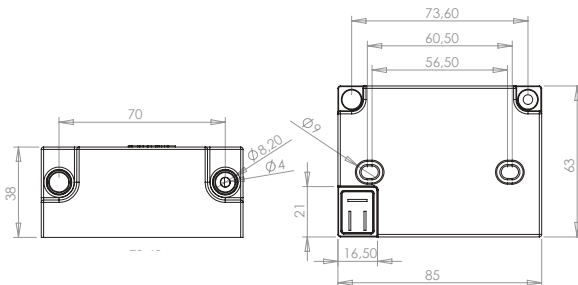

Inlet

Plug D

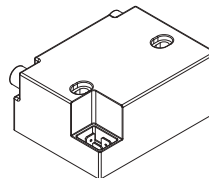

Outlet

H plug, horizontal output plug, \varnothing 4mm (13.5 mm deep)

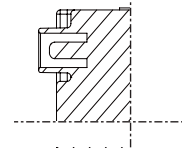

Type	Vin	Pin	Iout cc	Iout burn*	Vout	ED	Ta	Output	Note
INTERMITTENT									
TRK2-30PHD	220-240V	63W	30 mA	20 mA	1x15 kV	33% on 3'	60°C	Grounded pole	
TRK2-40PHD	220-240V	65W	40 mA	24 mA	1x15 kV	33% on 3'	60°C	Grounded pole	

*Current measured on the burner with 5mm spark gap, blowing air and suppressed cables.

Applications



Available certification



Transformer 4th generation and new concept, which incorporates all the experience and knowledge, accumulated in over 20 years of electronic design and production, is able to combine excellent power performance at a very affordable price.

TRJ

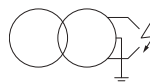

2 POLES

17

Technical drawing [mm]

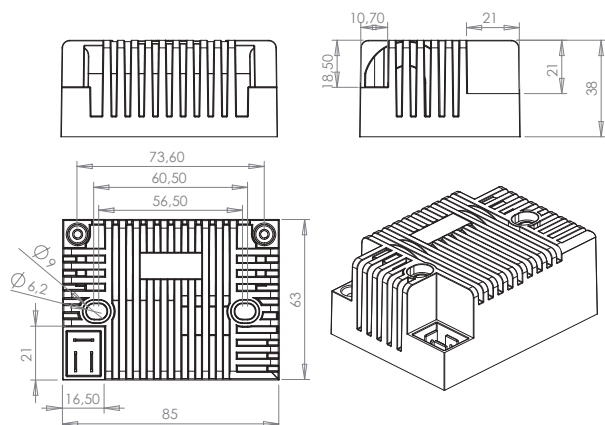

Inlet

Plug D

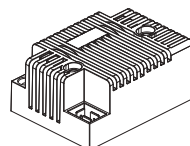

Outlet

V plug, vertical output plug, Ø 4mm

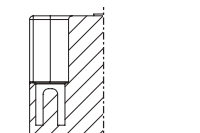

BEST PRICE

Type	Vin	Pin	Iout cc	Iout burn*	Vout	ED	Ta	Output	Note
CONTINUOUS 100%									
TRJ1-20CVD	220-240V	30W	20 mA	12 mA	2x14 kV	100%	60°C	Grounded center	CE
INTERMITTENT									
TRJ2-30VD	220-240V	65W	35 mA	21 mA	2x10 kV	33% su 3'	60°C	Grounded center	CE

*Current measured on the burner with 5mm spark gap, blowing air and suppressed cables.



1 POLE

Technical drawing [mm]

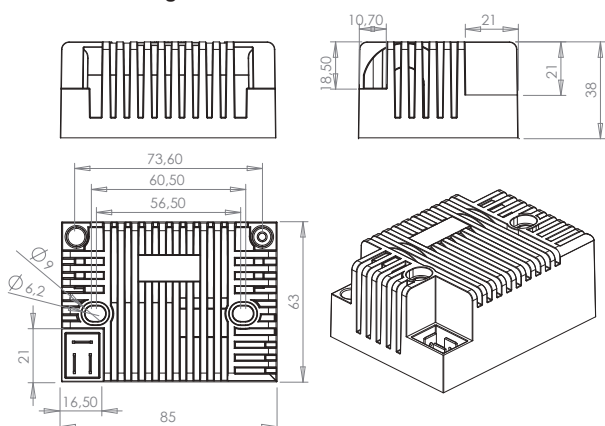

Inlet

Plug D

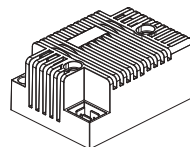

Outlet

V plug, vertical output plug, Ø 4mm

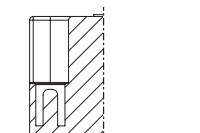

Type	Vin	Pin	Iout cc	Iout burn*	Vout	ED	Ta	Output	Note
INTERMITTENT									
TRJ2-30PVD	220-240V	63W	30 mA	20 mA	1x15 kV	33% su 3'	60°C	Grounded pole	CE

*Current measured on the burner with 5mm spark gap, blowing air and suppressed cable.

Applications



Available certification



TRJ3

Vertical outlet | Plug D

18

2 POLES



Adaptive power transformer

It is always supplying the maximum available power depending on environmental and duty conditions. The power of an intermittent transformer that adapt itself at an eventual continuous duty.

Technical drawing [mm]

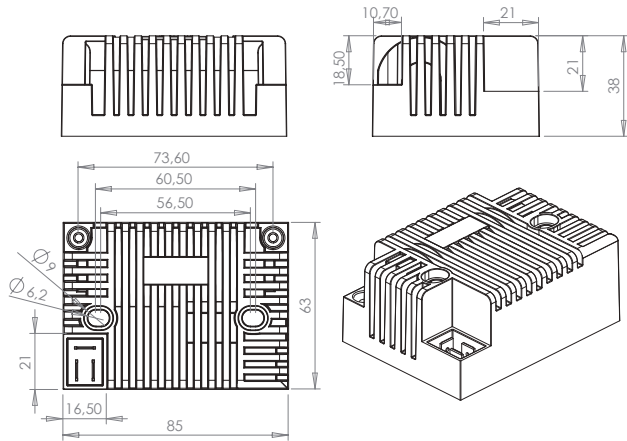

Inlet

Plug D

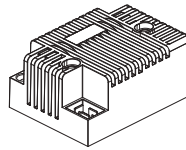

Outlet

V plug, vertical output plug, Ø 4mm

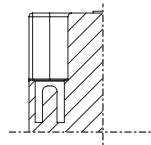

**SMART
IGNITION**

Type	Vin	Pin	Iout cc	Iout burn*	Vout	ED	Ta	Output	Note
CONTINUOUS 100%									
TRJ3-40CVD	220-240V	65W	30 mA	26-18 mA	2x14 kV	100%	60°C	Grounded center	CE

*Current measured on the burner with 5mm spark gap, blowing air and suppressed cables.

Transformer with a sophisticated temperature control able to take advantage of the environmental conditions to maximize the benefits provided. As long as the temperatures or duty cycles do not exceed certain conditions, the transformer provides the maximum current of 26mA, for example in the event of ignition in cold climates or after long periods of inactivity. In any case guarantees a 100% continuous service with actual 18mA up to 60 °C ambient temperature. It can be applied in any application that has very tight insertion cycles of always providing the maximum power available and self-limiting only in extreme environmental conditions.

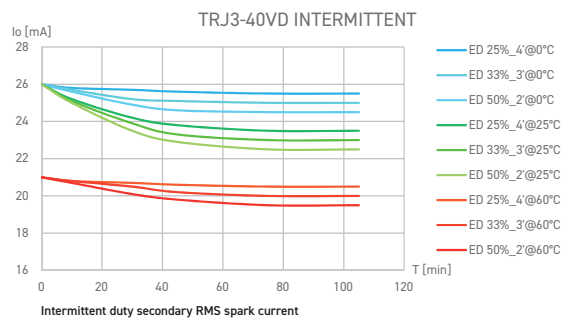
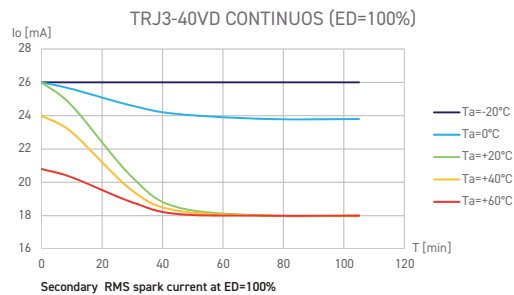

Applications



Available certification



24 Vdc igniter of compact size with 1 pole, designed for gas applications which do not require high power levels and still fed in systems with portable generators where there is no power line.

TRM



1 POLE

19

Technical drawing [mm]

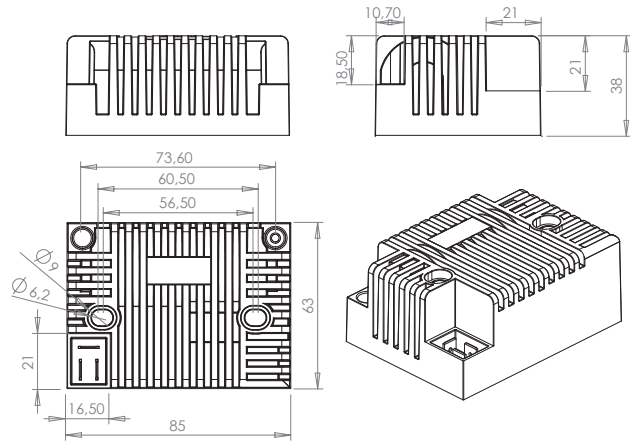

Inlet

Plug D

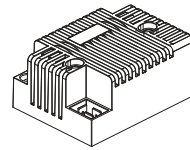

Outlet

V plug, vertical output plug, Ø 4mm

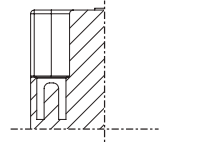

**24Vdc
MIDDLE
POWER**

Type	Vin	Pin	Iout cc	Iout burn*	Vout	ED	Ta	Output	Note
CONTINUOUS 100%									
TRM24-20PCVD	24Vdc	40W	20 mA	14 mA	1x15 kV	100%	60°C	Grounded pole	CE

*Current measured on the burner with 5mm spark gap, blowing air and suppressed cables.

Applications



Available certification



TRL

Vertical outlet | Plug D



High power transformers and sophisticated technology capable of meeting the most stringent requirements demanding high power and extension of the limits of use in extreme temperatures, in off shore and portable systems with supply voltage 12 and 24 Vdc, continuous duty for oil and gas applications .

20

2 POLES



12 V_{dc}
24 V_{dc}

HIGH
POWER

Technical drawing [mm]

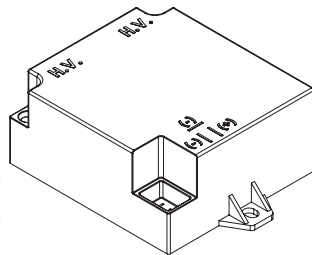
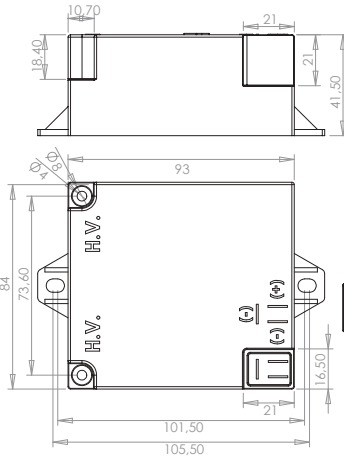

Inlet

Plug D

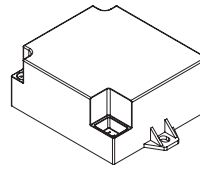

Outlet

V plug, vertical output plug, Ø 4mm

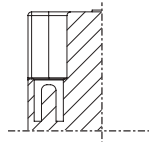

Type	Vin	Pin	Iout cc	Iout burn*	Vout	ED	Ta	Output	Note
TRL12-30C	12Vdc	80W	30 mA	22 mA	2x12kV	100%	60°C	Grounded center	CE
TRL24-30C	24Vdc	80W	30 mA	22 mA	2x12kV	100%	60°C	Grounded center	CE

*Current measured on the burner with 5mm spark gap, blowing air and suppressed cables.

1 POLE



Technical drawing [mm]

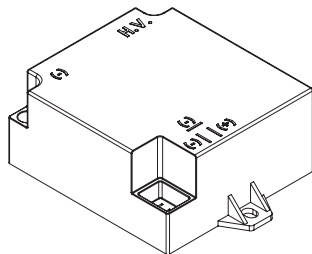
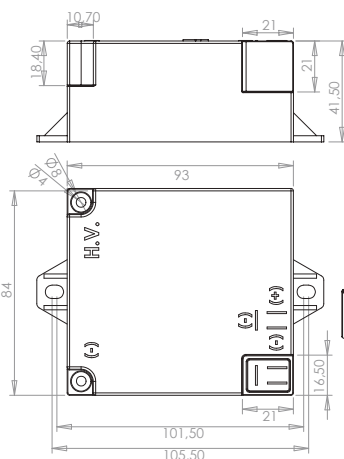

Inlet

Presa per spina D

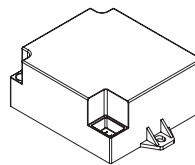

Outlet

V plug, vertical output plug, Ø 4mm

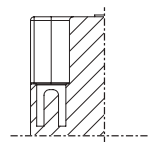

Type	Vin	Pin	Iout cc	Iout burn*	Vout	ED	Ta	Output	Note
TRL12-30PC	12Vdc	80W	30 mA	22 mA	1x15kV	100%	60°C	Grounded pole	CE
TRL24-30PC	24Vdc	80W	30 mA	22 mA	1x15kV	100%	60°C	Grounded pole	CE

*Current measured on the burner with 5mm spark gap, blowing air and suppressed cables.

Applications



Available certification



High power transformers and sophisticated technology able to meet the most stringent requirements that ask great power and extension of the limits of use at extreme temperatures. The transformers of this series are available in both continuous and intermittent service and supply voltages for all world markets from 120 to 400V.



TRH

Vertical outlet | Plug D

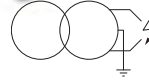

2 POLES

21

Technical drawing [mm]

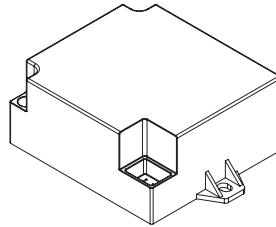
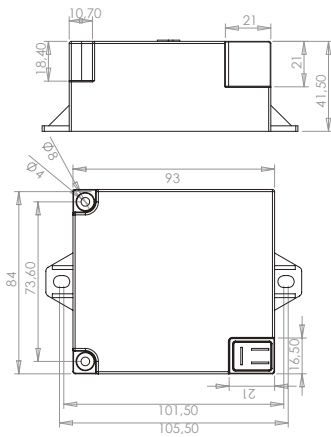

Inlet

Plug D

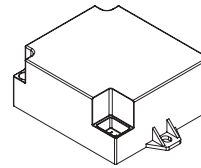

Outlet

V plug, vertical output plug, Ø 4mm

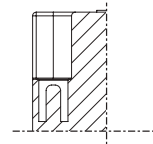

**HIGH
POWER**

Type	Vin	Pin	Iout cc	Iout burn*	Vout	ED	Ta	Output	Note
CONTINUOUS 100%									
TRH2-30CU	120V	70W	30 mA	25 mA	2x12 kV	100%	60°C	Grounded center	CE
TRH2-30C	230V	60W	30 mA	25 mA	2x12 kV	100%	60°C	Grounded center	CE
TRH2-30CQ	400V	60W	30 mA	25 mA	2x12 kV	100%	60°C	Grounded center	CE
INTERMITTENT									
TRH2-60	230V	100W	50 mA	30 mA	2x12 kV	33% on 3'	60°C	Grounded center	CE
TRH2-40U	120V	90W	40 mA	30 mA	2x12 kV	33% on 3'	60°C	Grounded center	CE

*Current measured on the burner with 5mm spark gap, blowing air and suppressed cables.

Applications



Available certification



TRW1



Ignition transformer with capacitive discharge technology for applications in condensing boilers and atmospheric gas burners. Developed to produce more power to the classics on board lighters, filtered against electromagnetic interference and available with output for mono-electrode flame detection.

2 POLES

22

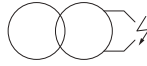

One pole shall be grounded.

Technical drawing [mm]

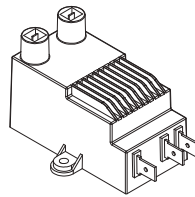
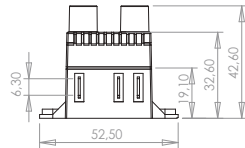
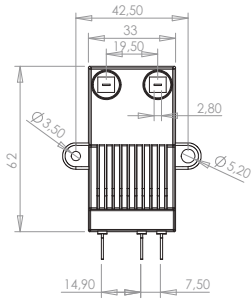

Inlet

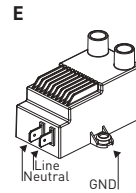
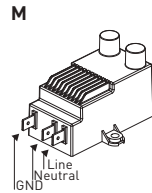

Outlet | Uscite

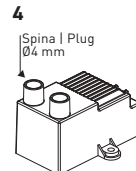
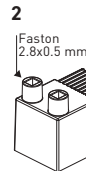

CONDENSING BOILERS

Type	Vin	Pin	Iout pick	Energy*	Vout	ED	Ta	Output	Note
TRW1S2E	220-240V	5W	800mA	20 mJ	15 kV	100%	60°C	Insulated	CE
TRW1S2M1	220-240V	5W	800mA	20 mJ	15 kV	100%	60°C	Insulated	CE
TRW1S4E	220-240V	5W	800mA	20 mJ	15 kV	100%	60°C	Insulated	CE

*Measured on 2k ohm resistor.

1 POLE



Technical drawing [mm]

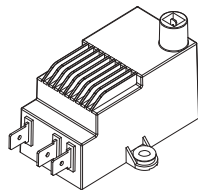
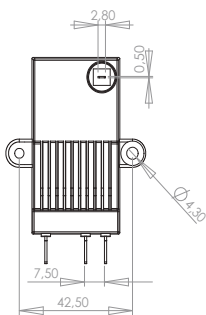

Inlet

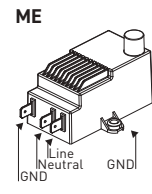
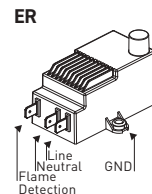
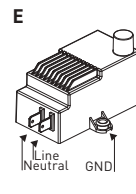
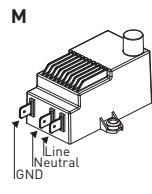

Outlet

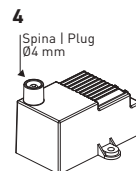
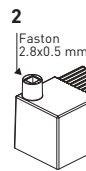

Type	Vin	Pin	Iout pick	Energy*	Vout	ED	Ta	Output	Note
TRW1P2M	220-240V	5W	800mA	20 mJ	1x15 kV	100%	60°C	Grounded pole	CE
TRW1P2E	220-240V	5W	800mA	20 mJ	1x15 kV	100%	60°C	Grounded pole	CE
TRW1P2ER	220-240V	5W	800mA	20 mJ	1x15 kV	100%	60°C	Grounded pole	CE
TRW1P2ME	220-240V	5W	800mA	20 mJ	1x15 kV	100%	60°C	Grounded pole	CE
TRW1P4M	220-240V	5W	800mA	20 mJ	1x15 kV	100%	60°C	Grounded pole	CE
TRW1P4E	220-240V	5W	800mA	20 mJ	1x15 kV	100%	60°C	Grounded pole	CE
TRW1P4ER	220-240V	5W	800mA	20 mJ	1x15 kV	100%	60°C	Grounded pole	CE
TRW1P4ME	220-240V	5W	800mA	20 mJ	1x15 kV	100%	60°C	Grounded pole	CE

*Measured on 2k ohm resistor

Applications



Available certification



TRW2



1 POLE

23

Technical drawing [mm]

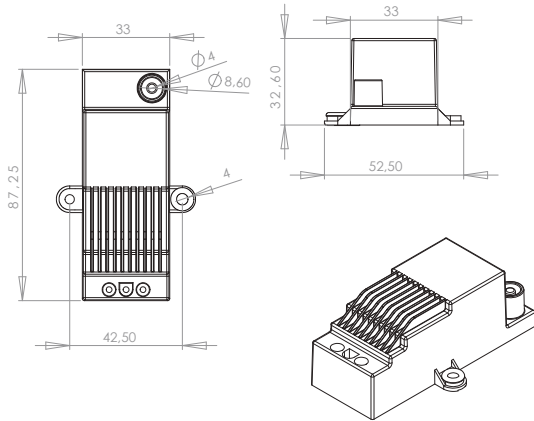

Inlet

M

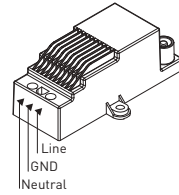

RE

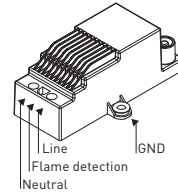

Outlet

4

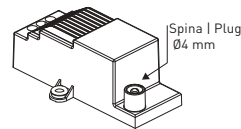

**CONDENSING
BOILERS**

Type	Vin	Pin	Iout pick	Energy*	Vout	ED	Ta	Output	Note
TRW2P4M	220-240V	5W	800mA	20 mJ	1x15 kV	100%	60°C	Grounded pole	CE
TRW2P4ER	220-240V	5W	800mA	20 mJ	1x15 kV	100%	60°C	Grounded pole	CE

*Measured on 2k ohm resistor.

Applications



Available certification



TRUP

Direct outlet | Plug A

24

2 POLES

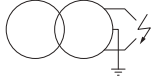

Top Mounted Ignition Transformer
Transformer specially designed to be mounted directly on the burner head, it does not require ignition cables and is already supplied with internal EMC noise suppression filters.



Technical drawing [mm]

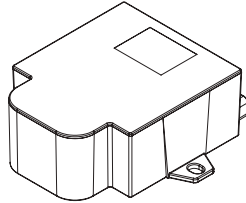
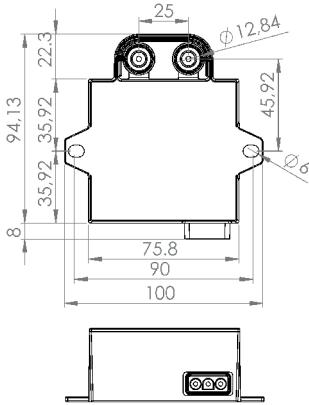

Inlet

Plug A

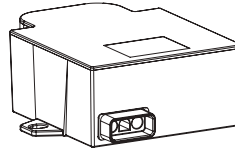

Outlet

Direct connection too the cleaner electrodes with spring for A 6,3mm male electrod

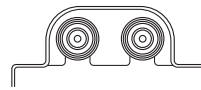

STANDARD

Type	Vin	Pin	Iout cc	Iout burn*	Vout	ED	Ta	Output	Note
CONTINUOUS 100%									
TRUP25-30C	220-240V	30W	30 mA	17 mA	2x12 kV	100%	60°C	Grounded center	CE

*Current measured on the burner with 5mm spark gap, blowing air and suppressed cables.

Available certification



TRXXPX-ISO

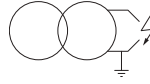
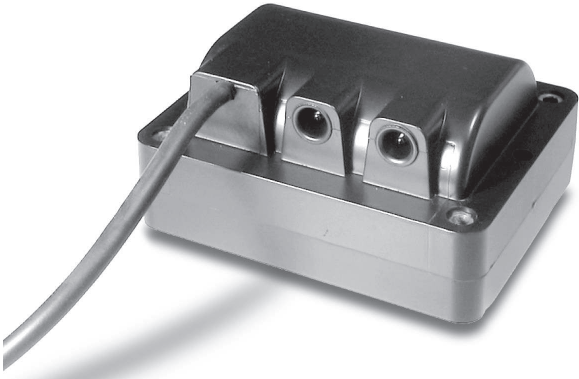

SEO
Single electrode operation 25

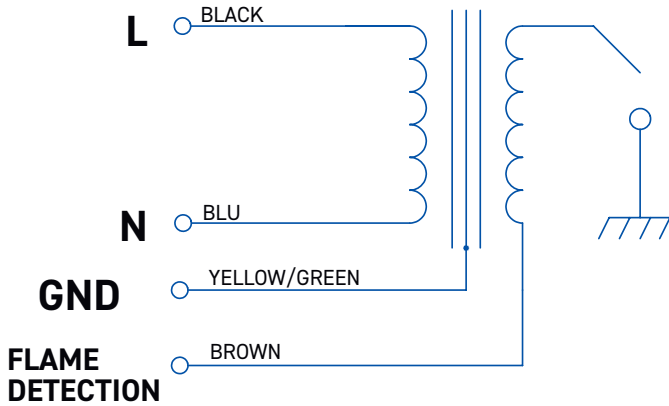

Transformer built with a special double insulation on the secondary which allows the separation of the winding principle, in such a way as to make it compatible with flame control equipment that uses the flame detection system single electrode. In these types of systems, the winding principle is connected to earth during ignition via a relay, while it is connected to the flame control amplifier input, to monitor the ionization current once completed the ignition phase. It is available in different power and duty cycle versions, as well as intermittent and continuous service.

Type	Vin	Freq	Vout	Iout	ED	Output	Note
INSULATED*							
TRE510PCISO	230V	50Hz	1x5 kV	10 mA	100%	Insulated	CE
TRE515PISO	230V	50Hz	1x5 kV	15 mA	19% on 3'	Insulated	CE
TRE820PISO	230V	50Hz	1x8 kV	20 mA	19% on 3'	Insulated	CE
TRS820PISO*	230V	50Hz	1x8 kV	20 mA	33% on 3'	Insulated	CE
TRS515PCISO	230V	50Hz	1x5 kV	15 mA	100%	Insulated	CE
TRS812PCISO	230V	50Hz	1x8 kV	12 mA	100%	Insulated	CE

*Transformers used with control box designed for igniting and flame detecting.

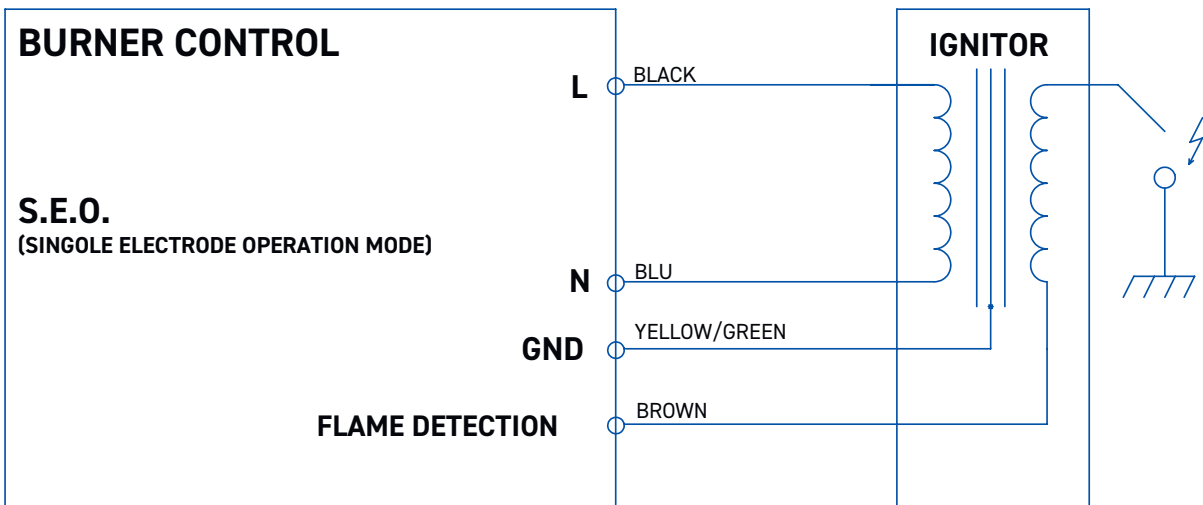

One pole inductive ISO transformer
Internal winding connection

Available certification



2 POLES

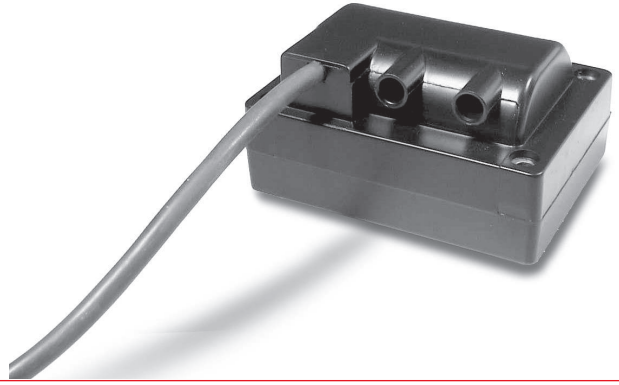

Technical drawing [mm]

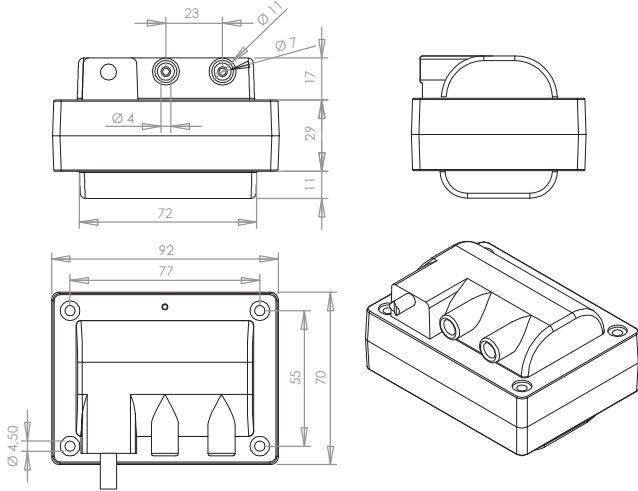

Inlet

Standard buried cable L=380mm

COFI plug

Triangle plug

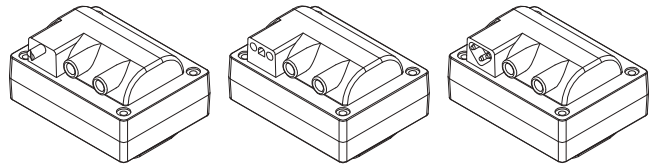

Outlet

Cod: SPRO

Cod: VIRAS

Cod: SPRAS

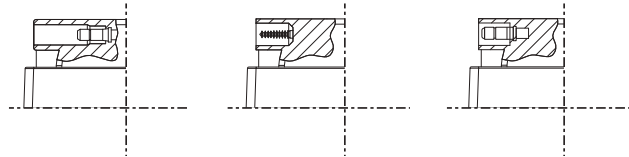

Type	Vin	Freq	Vout	Iout	ED	Output	Note
CONTINUOUS 100%							
TRE308C	230V	50Hz	2x1,5 kV	8 mA	100%	Grounded center	CE
TRE510C	230V	50Hz	2x2,5 kV	10 mA	100%	Grounded center	CE
INTERMITTENT							
TRE820	230V	50Hz	2x4 kV	20 mA	19% on 3'	Grounded center	

Applications



Available certification



Small dimension inductive transformer, it achieves the same performances of medium size transformers with lower costs, largely used for oil and gas burners, available with the secondary insulated for flame detection by ionization of the flame. It can also be applied to anti-mosquito equipment or ozone generators.

Available powersupply voltages
100V - 400 Vac

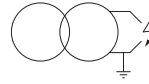

1 POLE

Technical drawing [mm]

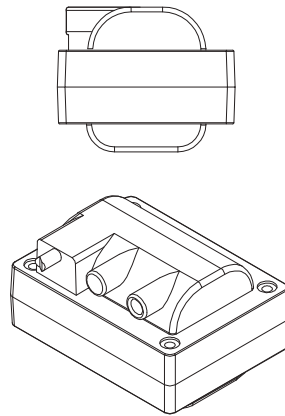
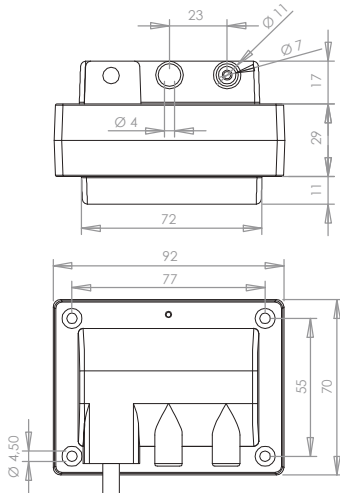

Inlet

Standard buried cable L=380mm

COFI plug

Triangle plug

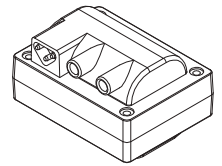
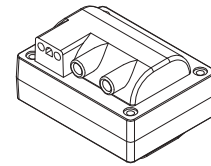
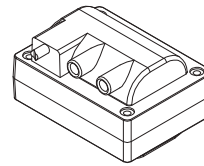

Outlet

Cod: SPRO

Cod: VIRAS

Cod: SPRAS

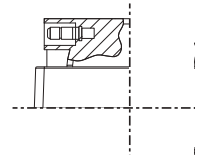
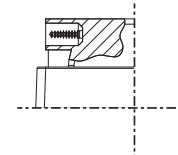
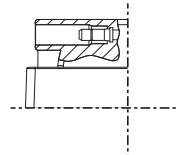

Type	Vin	Freq	Vout	Iout	ED	Output	Note
CONTINUOUS 100%							
TRE210PC	230V	50Hz	1x2 kV	10 mA	100%	Grounded pole	CE
TRE410PC	230V	50Hz	1x4 kV	10 mA	100%	Grounded pole	CE
TRE510PC	230V	50Hz	1x5 kV	10 mA	100%	Grounded pole	CE
TRE610PC	230V	50Hz	1x6 kV	10 mA	100%	Grounded pole	CE
INTERMITTENT							
TRE820P	230V	50Hz	1x8 kV	20 mA	19% on 3'	Grounded pole	CE
INSULATED*							
TRE510PCISO	230V	50Hz	1x5 kV	10 mA	100%	Insulated	CE
TRE515PISO	230V	50Hz	1x5 kV	15 mA	19% on 3'	Insulated	CE
TRE820PISO	230V	50Hz	1x8 kV	20 mA	19% on 3'	Insulated	CE

*Transformers used with control box designed for igniting and flame detecting.

Applications



Available certification



TRS

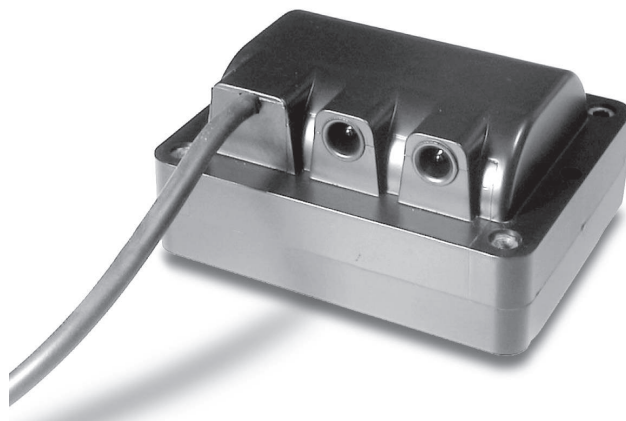

28

2 POLES

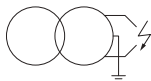

Technical drawing [mm]

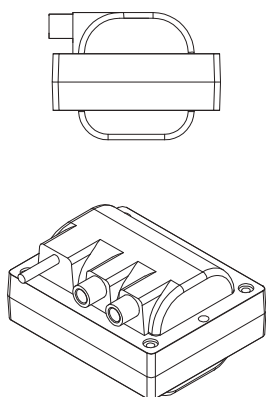
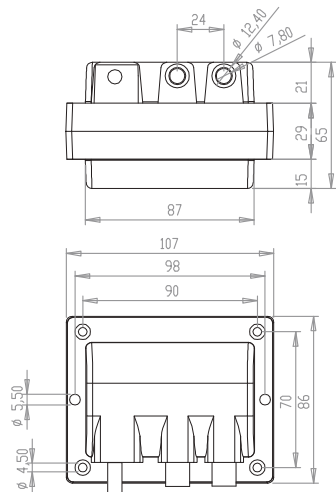

Inlet

Standard buried cable

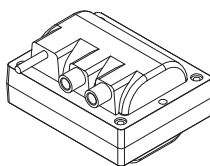

COFI plug

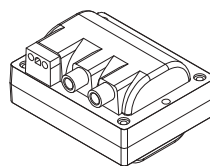

Triangle plug

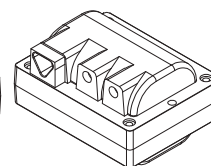

Outlet

Cod: SPRO

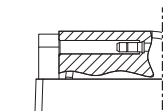

Cod: VIRAS

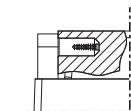

Cod: SPRAS

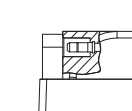

Cod: SPMAN

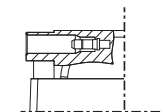

Cod: SP

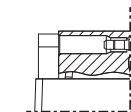

Cod: VIMAN

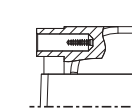

Type	Vin	Freq	Vout	Iout	ED	Output	Note
CONTINUOUS 100%							
TRS513C	230V	50Hz	2x2,5 kV	10 mA	100%	Grounded center	CE
TRS810C	230V	50Hz	2x4 kV	10 mA	100%	Grounded center	CE
TRS812C	230V	50Hz	2x4 kV	12 mA	100%	Grounded center	CE
TRS815C	230V	50Hz	2x4 kV	15 mA	100%	Grounded center	CE
TRS818C	230V	50Hz	2x4 kV	18 mA	100%	Grounded center	CE

INTERMITTENT

TRS820	230V	50Hz	2x4 kV	20 mA	25% on 4'	Grounded center	CE
TRS1020	230V	50Hz	2x5 kV	20 mA	25% on 4'	Grounded center	CE
TRS1020	230V	50Hz	2x5 kV	20 mA	33% on 3'	Grounded center	CE
TRS1030	230V	50Hz	2x5 kV	30 mA	25% on 4'	Grounded center	CE
TRS1220	230V	50Hz	2x6 kV	20 mA	25% on 4'	Grounded center	CE

Applications



Available certification



Medium-size inductive transformer, suitable for all kinds of gas and oil burners, where continuous or intermittent power and achievement of higher voltages and currents are required. This serie is available in a great number of variations. It suits very different uses such as burners, high-pressure cleaners, anti-mosquito electric equipment and ionizers.

Available powersupply voltages
100V - 400 Vac

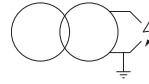

1 POLE

Technical drawing [mm]

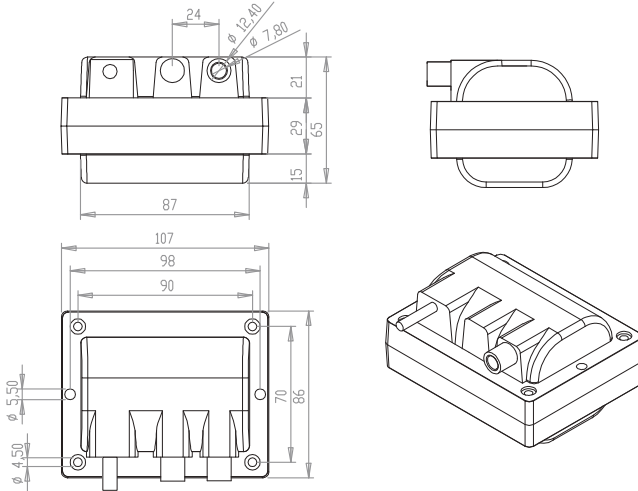

Inlet

Standard buried cable

COFI plug

Triangle plug

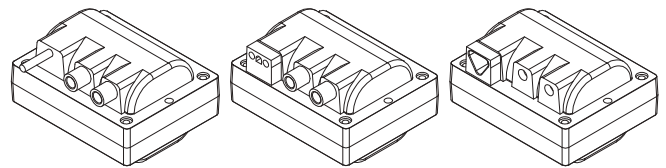

Outlet

Cod: SPRO

Cod: VIRAS

Cod: SPRAS

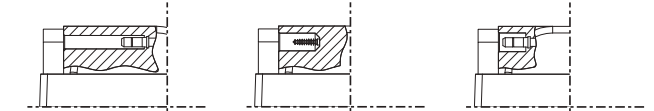

Cod: SPMAN

Cod: SP

Cod: VIMAN

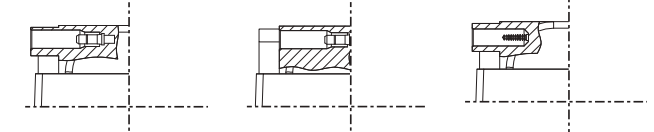

Type	Vin	Freq	Vout	Iout	ED	Output	Note
CONTINUOUS 100%							
TRS404PC	230V	50Hz	1x4 kV	4 mA	100%	Grounded pole	CE
TRS505PC	230V	50Hz	1x5 kV	5 mA	100%	Grounded pole	CE
TRS508PC	230V	50Hz	1x5 kV	8 mA	100%	Grounded pole	CE
TRS510PC	230V	50Hz	1x5 kV	10 mA	100%	Grounded pole	CE
TRS515PC	230V	50Hz	1x5 kV	15 mA	100%	Grounded pole	CE
TRS6.508PC	230V	50Hz	1x6,5 kV	8 mA	100%	Grounded pole	CE
TRS606PC	230V	50Hz	1x6,5 kV	6 mA	100%	Grounded pole	CE
TRS610PC	230V	50Hz	1x6,5 kV	10 mA	100%	Grounded pole	CE
TRS708PC	230V	50Hz	1x7 kV	8 mA	100%	Grounded pole	CE
TRS818PC	230V	50Hz	1x8 kV	18 mA	100%	Grounded pole	CE
TRS1815C/IS	230V	50Hz	1x2 kV	15 mA	100%	Grounded pole	CE

INTERMITTENT

TRS820P	230V	50Hz	1x8 kV	20 mA	25% on 4'	Grounded pole	
TRS723P US	120V	60Hz	1x8 kV	23 mA	25% on 4'	Grounded pole	
TRS830P	230V	50Hz	1x8 kV	30 mA	25% on 4'	Grounded pole	CE
TRS820PISO*	230V	50Hz	1x8 kV	20 mA	33% on 3'	Insulated	CE

*Transformers used with control box designed for igniting and flame detecting.

Applications



Available certification



2 POLES



Technical drawing [mm]

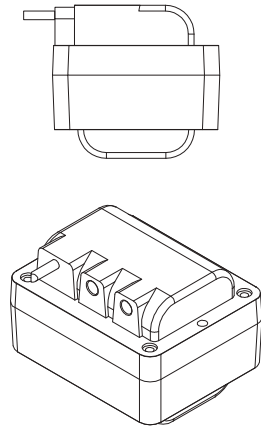
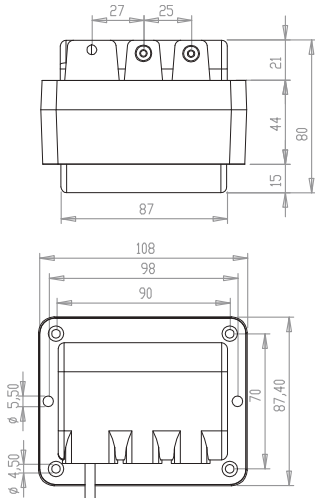

Inlet

Standard buried cable

COFI plug

Triangle plug

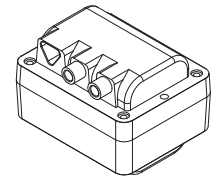
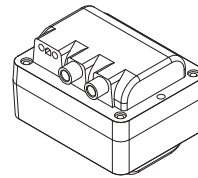
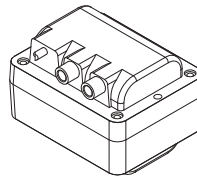

Outlet

Cod: SP

Cod: VIMAN

Cod: SPRAS

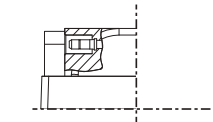
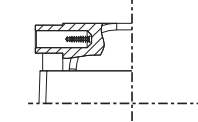
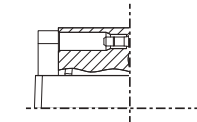

Cod: SPMAN

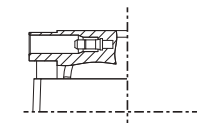

Type	Vin	Freq	Vout	Iout	ED	Output	Note
CONTINUOUS 100%							
TRG1015C	230V	50Hz	2x5 kV	15 mA	100%	Grounded center	CE
TRG1020C	230V	50Hz	2x5 kV	20 mA	100%	Grounded center	CE
INTERMITTENT							
TRG1035	230V	50Hz	2x5 kV	35 mA	25% on 4'	Grounded center	DE CE
TRG1035 US	120V	60Hz	2x5 kV	35 mA	25% on 4'	Grounded center	C UL US
TRG1225	230V	50Hz	2x6 kV	25 mA	25% on 4'	Grounded center	CE
TRG1230	230V	50Hz	2x6 kV	30 mA	33% on 3'	Grounded center	CE
TRG1230US	120V	60Hz	2x6 kV	30 mA	25% on 4'	Grounded center	C UL US

Applications



Available certification



Large-size inductive transformer, suitable for large-flow and heavy fuel burners, where continuous power and higher voltages or currents are required. The versions of this range are suitable for use in large-size transformers and industrial high-pressure cleaners.

Available powersupply voltages
100V - 400 Vac

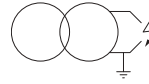

1 POLE

Technical drawing [mm]

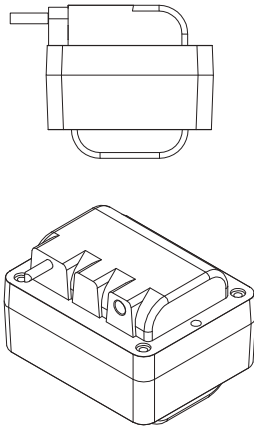
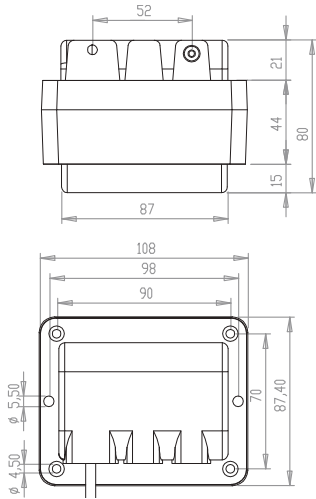

Inlet

Standard buried cable

COFI plug

Triangle plug

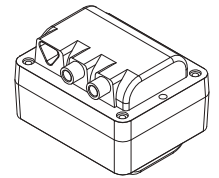
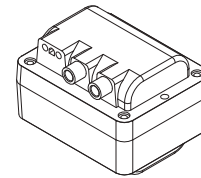
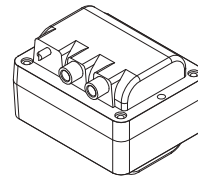

Outlet

Cod: SP

Cod: VIMAN

Cod: SPRAS

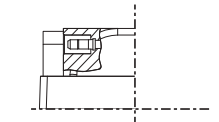
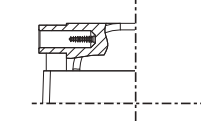
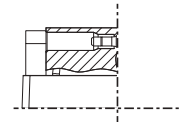

Cod: SPMAN

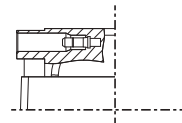

Type	Vin	Freq	Vout	Iout	ED	Output	Note
CONTINUOUS 100%							
TRG623PC US	120V	60Hz	1x6 kV	23 mA	100%	Grounded pole	
TRG820PC	230V	50Hz	1x8 kV	20 mA	100%	Grounded pole	
TRG1020PC	230V	50Hz	1x10 kV	20 mA	100%	Grounded pole	
INTERMITTENT							
TRG835P	230V	50Hz	1x8 kV	35 mA	25% on 4'	Grounded pole	
TRG1035P	230V	50Hz	1x10 kV	35 mA	25% on 4'	Grounded pole	

Applications



Available certification



TRZ

The smallest inductive transformer of the range, especially developed for the anti-mosquito equipments.



2 POLES

32



Technical drawing [mm]

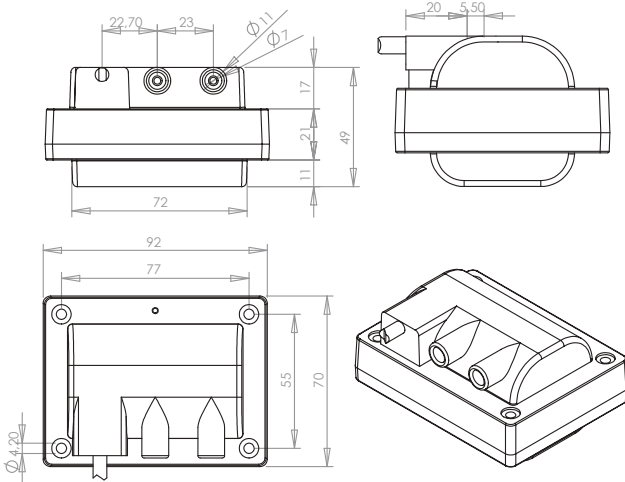

Inlet

Standard buried cable

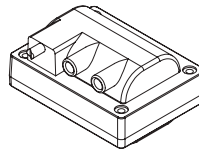

Outlet

Cod: SP

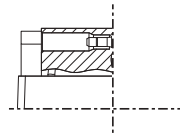

Type	Vin	Freq	Vout	Iout	ED	Output	Note
TRZ410C	230V	50Hz	2x2 kV	10 mA	100%	Grounded center	CE
TRZ510C	230V	50Hz	2x2,5 kV	10 mA	100%	Grounded center	CE

1 POLE

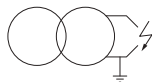

Technical drawing [mm]

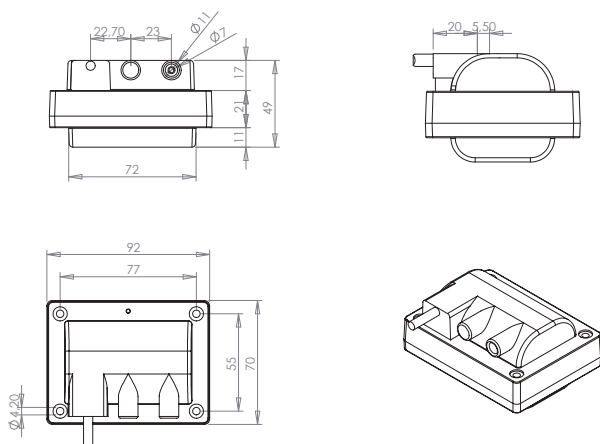

Inlet

Plug K

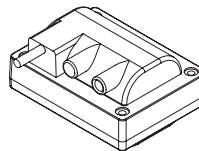

Outlet

Cod: SP

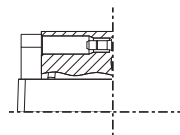

Type	Vin	Freq	Vout	Iout	ED	Output	Note
TRZ4.509PC	230V	50Hz	1x4,5 kV	9 mA	100%	Grounded pole	CE

Applications









Available certification

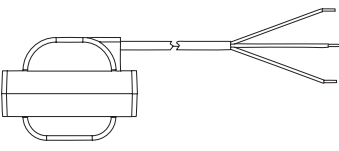

ACCESSORIES

PRIMARY CONNECTIONS

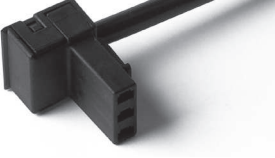
 <p>Standard buried cable</p>	 <p>Plug A</p>	 <p>Plug B</p>	 <p>Plug C</p>
 <p>Plug D</p>	 <p>Plug T</p>	 <p>Plug K</p>	

FILTERS



Inductive transformers
EMI disturbance
suppression filter
Code: **06CE061517**

MOUNTING BRACKETS



40X40 mm galvanized bracket
Bracket for horizontal mounting of transformer on any surface.
Code: **15MI152457**
Kit with screws and nuts available
Code: **Staffa 1**



102X26 mm galvanized bracket
Bracket for vertical mounting of transformer on any surface.
Code: **15MI152452**
Kit with screws and nuts available
Code: **Staffa 2**





ACCESSORIES

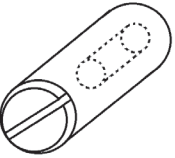

34 CONNECTIONS AND PROTECTIONS

 <p>Connector for faston 2,8x0,8mm for cable Ø5,2mm. Code: 11PC112031</p>	 <p>Bronze phosphor connector Ø 4mm for cable Ø 5,2mm Code: 11PC112020</p>	 <p>Bronze phosphor connector Ø 4mm for cable Ø 7mm Code: 11PC112010</p>	 <p>Bronze phosphor connector Ø 6,3 mm for cable Ø 5,2 / 7mm straight without spring Code: 11PC112013</p>
 <p>Bronze phosphor connector Ø 6,3 mm for cable Ø 5,2 / 7mm straight with spring Code: 11PC112011</p>	 <p>Bronze phosphor connector Ø 6,3 mm for cable Ø 5,2 / 7mm 90° with spring Code: 11PC112018</p>	 <p>PVC overmolded protection for Ø 4mm plug for cable Ø5,2 / 7mm Not available as parts Code: 17G0170000</p>	 <p>PVC overmolded protection for Ø 4mm 90° plug for cable Ø 5,2 / 7mm Not available as parts Code: 17G0ST000K</p>
 <p>Silicon Cap L=35mm for cable Ø 5,2 / 7mm Used with inductive transformer VIMAN and SPAN outlets Code: 17G0172601</p>	 <p>Type A PBT straight terminal cap for cables Ø 5,2 / 7mm Code: 04PL041442</p>	 <p>Silicone cap for Ø 6,3mm 90° plug connector for cables Ø 5,2 / 7mm Code: 17G0172605</p>	 <p>Silicone cap for Ø 4mm 90° plug connector for cables Ø 5,2 / 7mm Code: 17G0172604</p>

ADAPTERS

 <p>brass adapter from screw to 4mm plug to mount on the existing connection Code: 11PC112026</p>	 <p>tin plate brass adapter with spring from 6.3mm 90° connector to 4mm plug, to be mounted on the 90° connector (11PC112018) Code: 11PC112027</p>
---	--

HIGH-VOLTAGE CABLES

 <p>High Voltage Ø 7mm tear resistant silicone cable with resistive carbon fiber conductor (R=10kohm/m). Code: 09CA091868</p>	 <p>High Voltage Ø 5,2mm silicone tear resistant cable with resistive carbon fiber conductor (R=10kohm/m). Code: 09CA091869</p>	 <p>High Voltage 1x1 Ø7 mm tear resistant silicone cable with copper conductor. Code: 09CA091804</p>	 <p>High Voltage 1x1 Ø 5,2 mm tear resistant silicone cable with copper conductor. Code: 09CA091810</p>
---	---	---	---

FINISHED CABLE LENGTHS

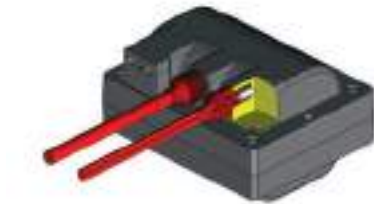

COFI realize primary and secondary silicone/copper or silicone/carbon fiber cables with custom-made lengths and finishing.



PVC PROTECTION | PROTEZIONI IN PVC

Over molded on the cable ensures perfect sealing of the transformer outputs for protection against humidity in dirty and contaminated environments.

Cofi manufactures high voltage ignition cable for all market needs. From the simple copper wire with connector to more complex cable with carbon fiber conductor, connector and moulded protections. The High voltage cables with resistive conductor in carbon fiber and semi-conductive rubber are used for shielding electromagnetic disturbances. Our EMC laboratory is fully equipped with instrument for EMC measurements for cable's and filters verifications.

TRANSFORMER INSTALLED IN IP65 BOX



TRANSFORMERS CODE SYSTEM

INDUCTIVE TRANSFORMERS CODE

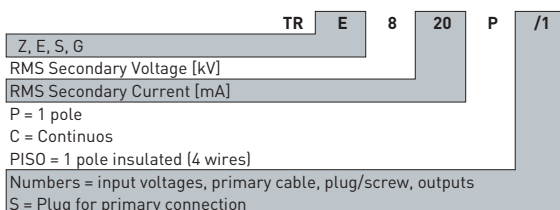

ELECTRONIC TRANSFORMERS CODE

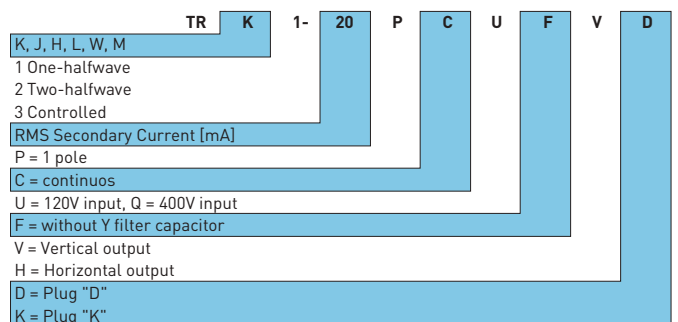

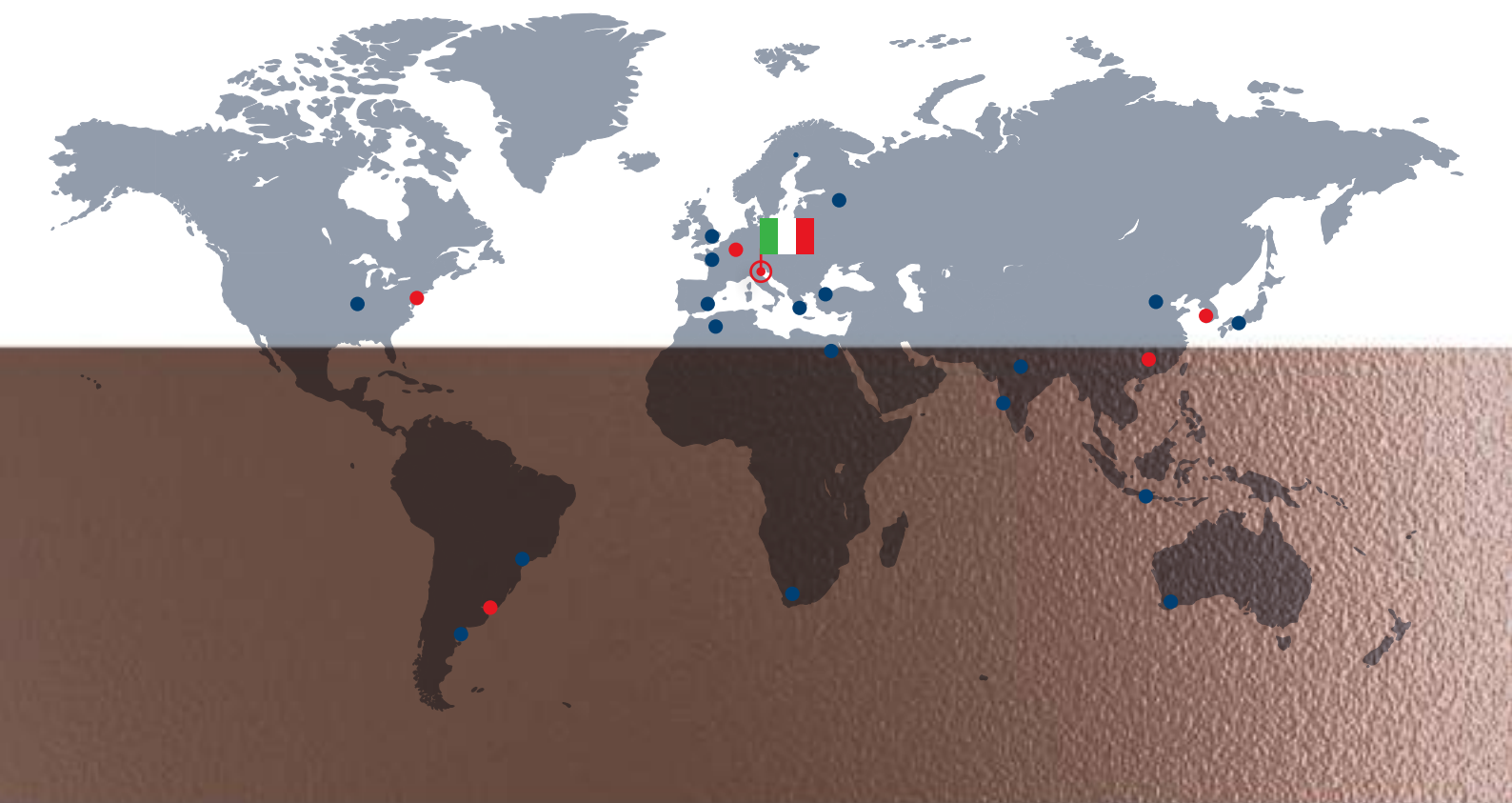

COFI srl
Via Castagnole, 58/A
31100 Treviso - ITALY

Tel. +39 0422 432 635
+39 0422 432 903

Fax +39 0422 432 802

Web www.cofisrl.it

E-mail cofi@cofisrl.it