

## Accessories



## High voltage cables and connectors

C-2 & C-5 & C-6 & C-7 & VS & GVR  
(E5001 rev. 02 - 17/04/2015)

## GENERAL WARNINGS:



■ All installation, maintenance, ignition and setting must be performed by qualified staff, respecting the norms present at the time and place of the installation.

■ To avoid damage to people and things, it is essential to observe all the points indicated in this handbook. The reported indications do not exonerate the Client/User from observing general or specific laws concerning accidents and environmental safeguarding.

■ The operator must wear proper DPI clothing (shoes, helmets...) and respect the general safety, prevention and precaution norms.

■ To avoid the risks of burns or high voltage electrocution, the operator must avoid all contact with the burner and its control devices during the ignition phase and while it is running at high temperatures.

■ All ordinary and extraordinary maintenance must be performed when the system is stopped.

■ To assure correct and safe use of the combustion plant, it is of extreme importance that the contents of this document be brought to the attention of and be meticulously observed by all personnel in charge of controlling and working the devices.

■ The functioning of a combustion plant can be dangerous and cause injuries to persons or damage to equipment. Every burner must be provided with certified combustion safety and supervision devices.

■ The burner must be installed correctly to prevent any type of accidental/undesired heat transmission from the flame to the operator or the equipment.

■ The performances indicated in this technical document regarding the range of products are a result of experimental tests carried out at ESA-PYRONICS. The tests have been performed using ignition systems, flame detectors and supervisors developed by ESA-PYRONICS. The respect of the above mentioned functioning conditions cannot be guaranteed if equipment, which is not present in the ESA-PYRONICS catalogue, is used.

## DISPOSAL:



To dispose of the product, abide by the local legislations regarding it.

## GENERAL NOTES:



■ In accordance to the internal policy of constant quality improvement, ESA-PYRONICS reserves the right to modify the technical characteristics of the present document at any time and without warning.

■ It is possible to download technical sheets which have been updated to the latest revision from the **www.esapyronics.com** website.

■ The products manufactured by ESA-PYRONICS have been created in conformity to the **UNI EN 746-2:2010** Norms: Equipment for industrial thermal process - Part 2: Safety requirements for combustion and the movement and treatment of combustible elements. This norm is in harmony with the Machine Directive **2006/42/CE**. It is certified that the products in question respect all the requirements prescribed by the above mentioned Norms and Directives.

■ Certified in conformity with the **UNI EN ISO 9001** Norm by DNV GL.

## CERTIFICATIONS:



The products comply with the requirements of the Eurasian market (Russia, Belarus and Kazakhstan) and are exempt from the EAC certification ref. **Doc. 01-11/437**

## CONTACTS / SERVICE:



### Headquarters:

Esa S.p.A.  
Via Enrico Fermi 40  
24035 Curno (BG) - Italy  
Tel +39.035.6227411  
Fax +39.035.6227499  
**esa@esacombustion.it**

### International Sales:

Pyronics International s.a.  
Zoning Industriel, 4ème rue  
B-6040 Jumet - Belgium  
Tel +32.71.256970  
Fax +32.71.256979  
**marketing@pyronics.be**

**www.esapyronics.com**

The special range of ESA HV cables and connectors are accessories used in High Voltage applications. They are specifically used in connections between ignition or detector electrodes with industrial burner control devices. Their particularity and the high quality of the material used to manufacture them guarantee a high reliability degree even in arduous working conditions.

## APPLICATIONS

- Rapid connection to electrodes for burners.
- High insulation degree connections and resistance to high temperatures.
- Decrease in EMC disturbance generated by burner ignition arching.
- Connectors for electrodes with 6,35 mm rayal terminals.
- Insulation of the active parts of the electrode.

## CHARACTERISTICS

### C-2 HV CONNECTOR

- Coupling electrode: female Rayal Ø 6.35mm
- Type of electrode attachment: spring-type
- HV connection: self-threading
- Type of HV cable: silicon (external diameter 7mm)
- Withstand voltage: 20KV
- EMC noise filter: absent
- Weight: 30g
- Protection degree: IP10
- Working temperature: -20÷300°C  
(see warnings chapter)
- Connector use: only ignition electrode
- Mounting position: any
- Insulation material: ceramic

### C-5 HV CONNECTOR

- Coupling electrode: female Rayal Ø 6.35mm
- Type of electrode attachment: spring-type
- HV connection: self-threading
- Type of HV cable: silicon (external diameter 7mm)
- Withstand voltage: 20KV
- EMC noise filter: present (1Kohm)
- Duty cycle noise filter : (see functioning chapter)
- Weight: 33g
- Protection degree: IP10
- Working temperature: -20÷150°C  
(see warnings chapter)
- Connector use: ignition and detection electrode
- Mounting position: any
- Insulation material: Rynite thermoplastic

C-2



F5001103

C-5



F5001105

## CHARACTERISTICS

### C-6 HV CONNECTOR

- Coupling electrode: female Rayal Ø 6.35mm
- Type of electrode attachment: spring-type
- HV connection: self-threading
- Type of HV cable: silicon (external diameter 7mm)
- Withstand voltage: 20KV
- EMC noise filter: present (1Kohm)
- Duty cycle noise filter: (see functioning chapter)
- Weight: 48g
- Protection degree: IP10
- Working temperature: -20÷250°C  
(see warnings chapter)
- Connector use: ignition and detection electrode
- Mounting position: any
- Insulation material: ceramic

C-6



F5001104

### C-7 HV CONNECTOR

- Coupling electrode: female Rayal Ø 6.35mm
- Type of electrode attachment: clip
- HV connection: self-threading
- Type of HV cable: silicon (external diameter 7mm)
- Withstand voltage: 20KV
- EMC noise filter: present (1Kohm)
- Duty cycle noise filter: (see functioning chapter)
- Weight: 45g
- Protection degree: IP10
- Working temperature: -20÷250°C  
(see warnings chapter)
- Connector use: ignition and detection electrode
- Mounting position: any
- Insulation material: ceramic

C-7



F5001108

## HV CABLE VS MODEL

- Cable type: unipolar
- Conductor cross section: 1mm<sup>2</sup>
- Conductor formation: 32x0,2mm
- Conductor material: tinned copper
- External cable diameter: 7,0 ± 0,2mm
- Insulation thickness: 2,85 ± 0,1mm
- Primary insulating material: silicon rubber  
white extruded
- Secondary insulating material: cover in fiberglass  
impregnated in silicon resin
- Insulation class: H
- Rated voltage: 1KV
- Peak voltage: 15KV
- Working temperature: -30÷220°C
- Maximum peak temperature: 280°C
- Minimum installation temperature: -50°C
- Minimum bending radius: 6 times the diameter
- Resistivity at 20°C: 17,6 ohm/Km
- Tensile strength: 60N/mm<sup>2</sup>
- Flame resistance: good, fire retardant
- Flexibility: excellent
- Resistance to hydrocarbons and solvents: scarce
- Resistance to mineral and vegetable oils: fair
- Resistance to light ageing: excellent
- Cable use: ignition and detection electrode  
connection

## HV CABLE GVR MODEL

- Cable type: unipolar
- Conductor cross section: 1mm<sup>2</sup>
- Conductor formation: 32x0,2mm
- Conductor material: copper
- External cable diameter: 7,2 ± 0,1mm
- Insulation thickness: 2,85 ± 0,1mm
- Primary insulating material: silicone rubber  
red extruded
- Secondary insulating material: cover in fiber  
glass impregnated in silicon resin
- Insulation class: H
- Rated voltage: 600V
- Peak voltage: 12KV
- Working temperature: -30÷180°C
- Maximum peak temperature: 220°C
- Minimum installation temperature: -50°C
- Minimum bending radius: 6 times the diameter
- Resistivity at 20°C: 19,1 ohm/Km

### VS



F5001106

### GVR



F5001107

- Tensile strength: 50N/mm<sup>2</sup>
- Flame resistance: good, fire retardant
- Flexibility: good
- Resistance to hydrocarbons and solvents: scarce
- Resistance to mineral and vegetable oils: fair
- Resistance to light ageing: good
- Cable use: ignition and detection electrode  
connection

## DESCRIPTION

The connectors and cables for HV (High voltage) are specific for the electric connection between burner ignition and detection electrodes and the relevant ignition transformers or flame control devices. The particularities of the HV cables make them suitable for any electrode of any shape and type that has a terminal diameter of 6,35mm. In some models, the coupling to the terminal of the electrode takes place thanks to a spring, ensuring thus constant electrical connection quality even after repeated operations of connection and disconnection or the presence of vibrations.

To ensure operator safety, the engagement seat of the terminal electrode is disposed inside the connector, so

that the metallic part of the electrode is totally inserted in it.

In their body the connectors have a self-tapping screw intended for the connection of the silicone cable, thus allowing a simple wiring which does not require the help of specific equipment or terminals for cables.

Depending on the application you can also choose between various ceramic HV connectors, resistant to high temperatures, or among those in Rynite® that have an excellent resistance to impact.

The HV cables have an excellent resistance to high temperatures and their size allows quick plugging on of all ESA Series TAR ignition transformers (E5004).

## FUNCTIONING

The function of the connectors and HV cables is to lead the current of the ignition discharge from the transformer to the electrode and vice versa conduct the flame signal current from the electrode to the control device.

Some HV connectors come with an EMC noise filter. They have the function of reducing electromagnetic disturbances generated by the ignition spark. These disturbances increase their intensity in proportion to the increase in the distance between the terminal point of the electrode in the burner and the metallic mass.

This distance must be less than the maximum distance allowed by the ignition transformer (see E5004).

The HV noise filter connector has an operation duty cycle which varies depending on the work temperature (tw) and on the current flowing through it.

The passage of only the current of the burner flame detection signal does not cause overheating of the connector while the current of the ignition discharge, depending on its intensity, reduces the operation duty cycle.

HV connector	Operation during flame detection with signal $I < 0.5 \text{ mA}$	Operation during burner ignition with HV current of $\leq 10 \text{ mA}$	Operation during burner ignition with HV current of $10 < I < 20 \text{ mA}$
<b>C-5 Model</b>	100% tw $\leq 150^\circ\text{C}$	100% tw $\leq 100^\circ\text{C}$	50% tw $\leq 100^\circ\text{C}$
<b>C-6 Model</b>	100% tw $\leq 250^\circ\text{C}$	100% tw $\leq 200^\circ\text{C}$	50% tw $\leq 200^\circ\text{C}$
<b>C-7 Model</b>	100% tw $\leq 250^\circ\text{C}$	100% tw $\leq 200^\circ\text{C}$	50% tw $\leq 200^\circ\text{C}$

The operation duty cycle behaviour of the HV connector is the same as the one of the ignition transformer therefore

you are requested to refer to the technical data sheet of the transformer TAR (E5004).

## APPLICATION EXAMPLES - HV CONNECTORS AND CABLES

The HV (high voltage) connectors and cables are used for the electrical connection of the ignition and flame detection electrodes of the burner, ignition transformer and the

burner control device

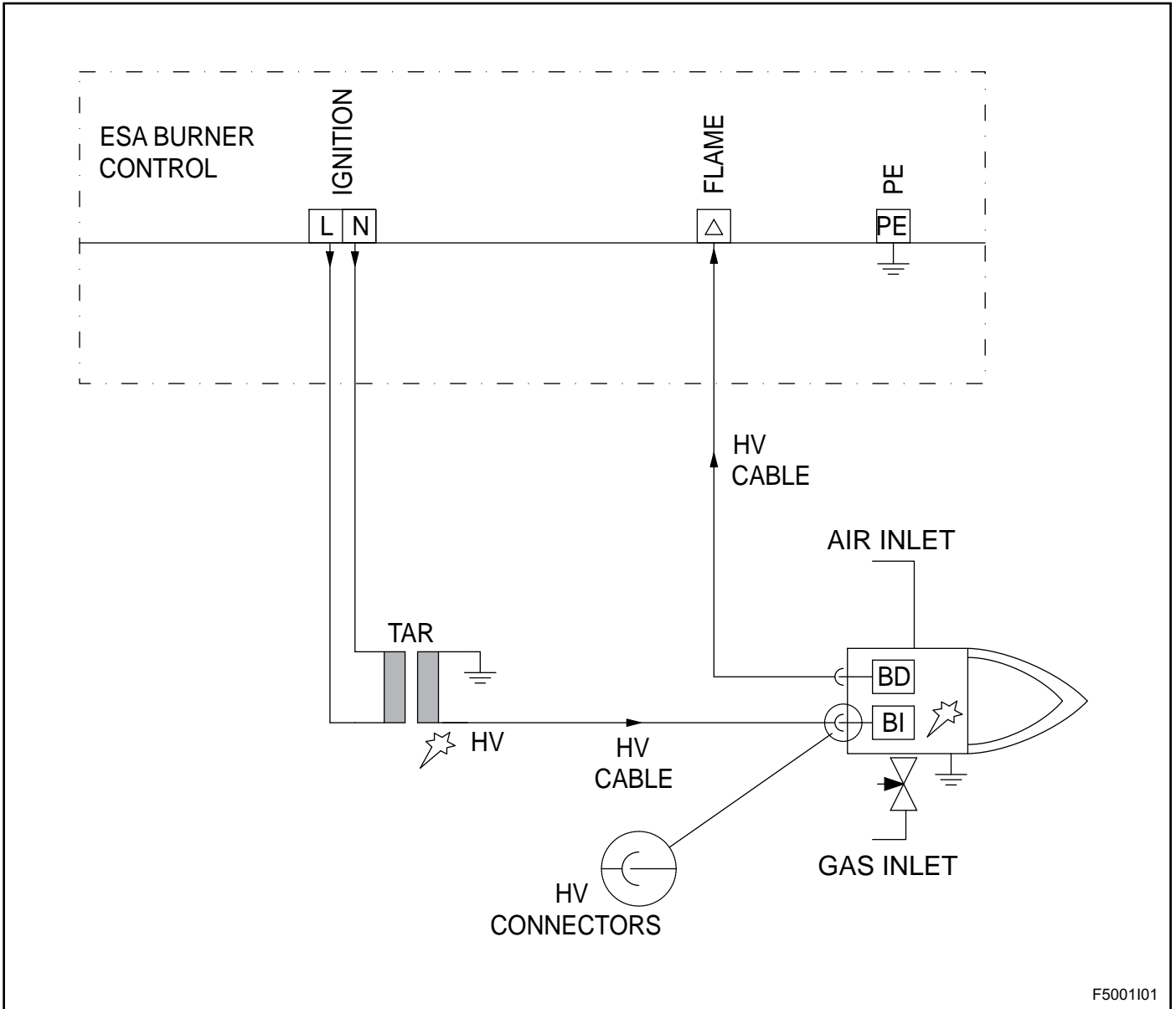

## WARNINGS

For a correct use of HV connectors and cables, follow these instructions.

■ When choosing the HV connector model one must consider the use of the electrode (whether only for ignition or for flame ignition and detection), of the operating duty cycle requested by the working temperature application. Before installing the device, check that the characteristics conform to what has been established.

■ When evaluating the working temperature for the HV connectors, take account of the sum between the environmental temperature and the temperature conducted to the outside by the burner electrodes, especially in the presence of preheated air burners or heavy duty applications.

■ The length of the ignition HV cable and that of the detection HV cable must not exceed the length allowed. Refer to the specific documentation of the TAR ignition transformers (E5004) or of the burner flame control devices to assess the maximum lengths allowed.

■ If the control device is not installed in the burner vicinity it is however advisable to use the HV cable to connect the flame detection signal to the control device. The benefits are given by the high insulation that reduces the dispersion of the ionization current, as well as the influence of coupled voltages on the cables.

■ Make sure that the HV cable from the ignition transformer and the relative HV connector, are connected to the burner ignition electrode before the system is energized. Failure to connect leads to irreparable damage and dangerous conditions for the application and operator.

■ To ensure the safety of the operator it is strictly forbidden to touch the cables, connectors and burner electrodes while the transformer or control device are operating, due to the high voltage present. Before carrying out any operation, make sure that you have disconnected the power to the TAR transformer and the control device.



## INSTALLATION

For correct installation, follow these instructions:

**1** - The installation must be carried out by qualified staff respecting the laws in force at the time and place of installation.

**2** - Place the HV cables and connectors so as not to expose them to direct radiation, heat or products resulting from combustion, such as corrosive liquids, solvents or gases.

**3** - Do not, in any way, restrict the area surrounding the HV connector, but guarantee enough space and ventilation to avoid the device from overheating.

**4** - Define the path of the HV cable between the ignition transformer and the relevant burner electrode so that it is far from the metallic masses and electronic control cards thus preventing the generation of electrical arcs along the path of the cable instead of on the burner electrode causing irreparable damage.

**5** - Take into account that the HV ignition cable must be separate from other conductors especially from flame detection cables, cables with signals and device power cables. Placing them near ignition cables coming from other ignition transformers is also not admitted. Furthermore the HV ignition cable cannot be placed in metallic conduits. Ideally it should be left in open air.

**6** - Before positioning the HV ignition cable in the chosen path, connect it to the ignition transformer. Screw the cable into the mount with the self-tapping screw in the ignition transformer, applying discreet pressure in the direction of the fitting. At the end check that you are connected by pulling slightly to the outside and check that the insulation of the cable is fully inserted in the fitting.

**7** - Position the HV cable up to the ignition electrode bearing in mind that the path must be as short as possible. If necessary leave a loop with small surplus of cable for future maintenance, while leaving excess HV cable is not allowed (spirals are not allowed).

**8** - Once the HV cable length has been defined in the burner vicinity, screw on the cable of the special connection with the self-tapping screw in the HV connector applying discreet pressure in the direction of the fitting. At the end check that you are connected by pulling slightly to the outside and check that the insulation of the cable is fully inserted in the fitting.

**9** - Insert the HV connector in the burner electrode to complete the connection. To facilitate the hooking push the connector on the terminal electrode using discreet pressure in the direction of the burner and simultaneously sway the connector so as to facilitate the hooking of the spring. At the end check that you are connected by pulling slightly to the outside and check that the insulation of the cable is fully inserted in the fitting.

**10** - The ignition electrodes and possible connectors must be insulated and made inaccessible by using appropriate protection so as to allow access only to qualified personnel; if necessary, put warning signs near the probes.

**INSTALLATION**

**ITINERARY CHOICE HV CABLE**

**OPTIMAL CONDITIONS**

HV/TAR burner silicone cable left in open air.

D5001102

**NOT RECOMMENDED CONDITIONS**

HV/TAR burner silicone cable passing through plastic pipes

□ material: PP - PE - PVC

D5001103

**HIGHLY NOT RECOMMENDED CONDITIIONS**

HV/TAR burner silicone cable passing through metal pipes.

■ material: Cro Ni - Al - Cu - Fe

D5001104

**HIGHLY NOT RECOMMENDED CONDITIIONS**

more HV/TAR burner silicone cables passing through the same metal or plastic pipe.

■ material: Cro Ni - Al - Cu - Fe

□ material:PP - PE - PVC

D5001105

**HV VABLE LENGTH**

HV cable see technical data sheet E5001

**N.B. respect the maximum cable length allowed according to the transformer model chosen referring to the "Warnings" paragraph on page 7**

D5001106

## INSTALLATION

### CONNECTION OF THE HV CABLE TO THE IGNITION TRANSFORMER

1 - Insert the HV cable in the special connection of the TAR series ignition transformer

2 - Screw the HV cable onto the self-tapping screw exerting discreet pressure in the direction of the connection.

3 - Check that the HV cable has indeed been connected pulling lightly in the opposite direction to the connection.

D5001107

### CONNECTION OF THE HV CABLE TO THE HV CONNECTOR FOR THE ELECTRODE

1 - Insert the HV cable into its appropriate connection on the electrode connector

2 - Screw the HV cable onto the self-tapping screw exerting discreet pressure in the direction of the connection.

3 - Check that the HV cable has indeed been connected pulling lightly in the opposite direction to the connection

D5001108

## INSTALLATION

### INSERTION OF BURNER ELECTRODE HV CONNECTOR

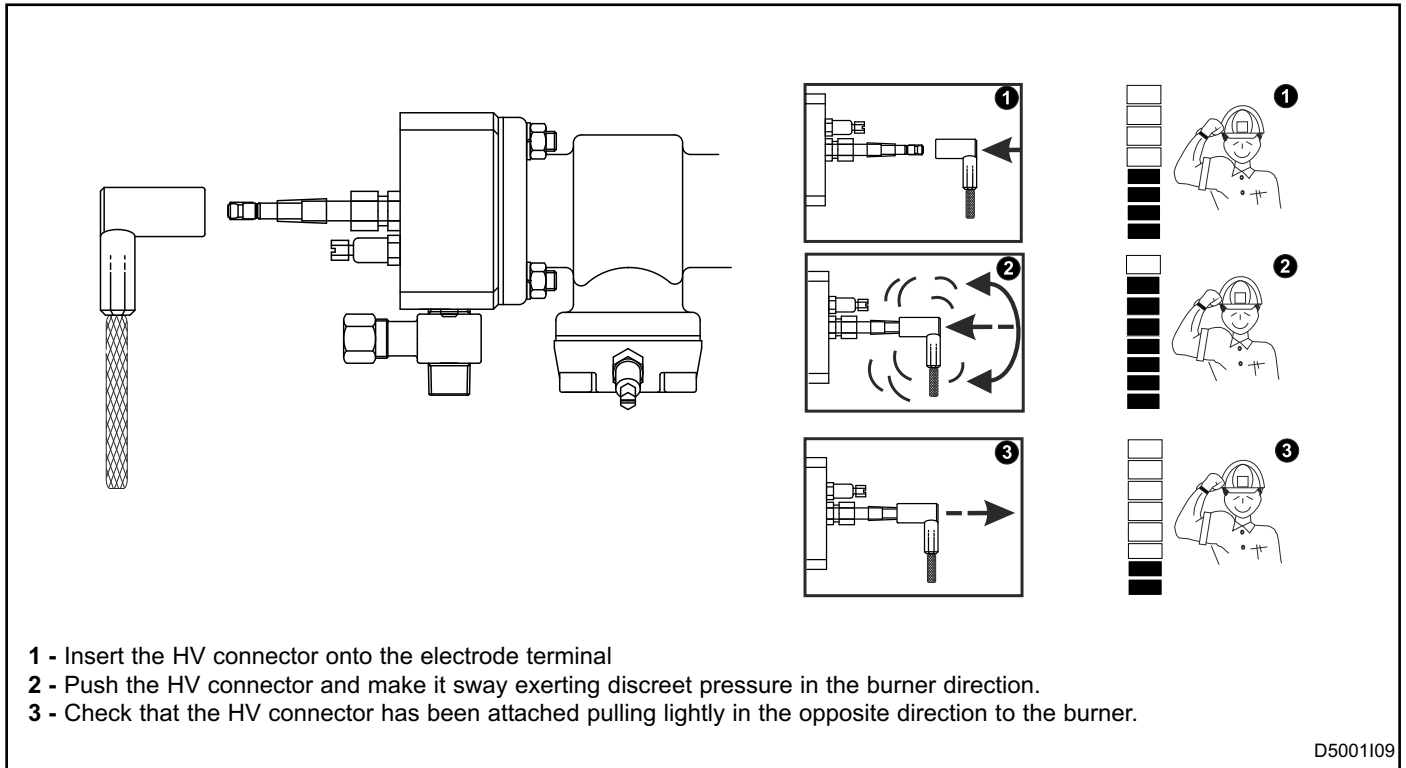

D5001109

## GENERAL MAINTENANCE PLAN

Operation	Type (*)	Advised time	Note
<b>Integrity of cable connections</b>	O	every six months	Check integrity of external insulation and absence of abrasions or conductor overheating signs.
<b>Fastening of conductors</b>	S	annual	Reduce to every six months for applications with vibrations.
<b>Replacement of HV connector or cable</b>	S	/	Replacement is necessary if the device is damaged

**NOTES:**

Key: O = ordinary / E = extraordinary

## ORDINARY MAINTENANCE

For correct maintenance of the HV connectors and cables, scrupulously follow the instructions below. Before carrying out any operations with the plant on, make sure that the process and operator safety are not in any way compromised. If necessary operate with plant off.

### INTEGRITY CHECK

The integrity of the HV cable can be checked visually. In case it is necessary to operate on the conductors for verification, as they are not completely visible, disconnect the power to the control device and ignition transformer before carrying out any type of operation.

## EXTRAORDINARY MAINTENANCE

For correct maintenance of the HV cables and connectors scrupulously follow the instructions below with the plant off.

ble. Disconnect the electric supply to the TAR transformer and control device before performing this check.

### FASTENING OF CONDUCTORS

Checking involves the connection of the HV cable on the output of the HV ignition transformer and connector. Apply gentle traction in the opposite direction to the connection to check that the cable is properly connected and visually check that the insulation of the cable is fully inserted in the seat of the connector so no parts of the conductor are visi-

### REPLACEMENT OF THE HV CABLE OR CONNECTOR

- 1** - Make sure that the element to be replaced is in fact damaged and that you have a spare device that is exactly the same as the one that needs replacement.
- 2** - Disconnect the electric supply and then remove the damaged element.
- 3** - Install the new element scrupulously following the instructions indicated in the "Installation" chapter.

**OVERALL DIMENSIONS FOR HV C-2 CONNECTOR**

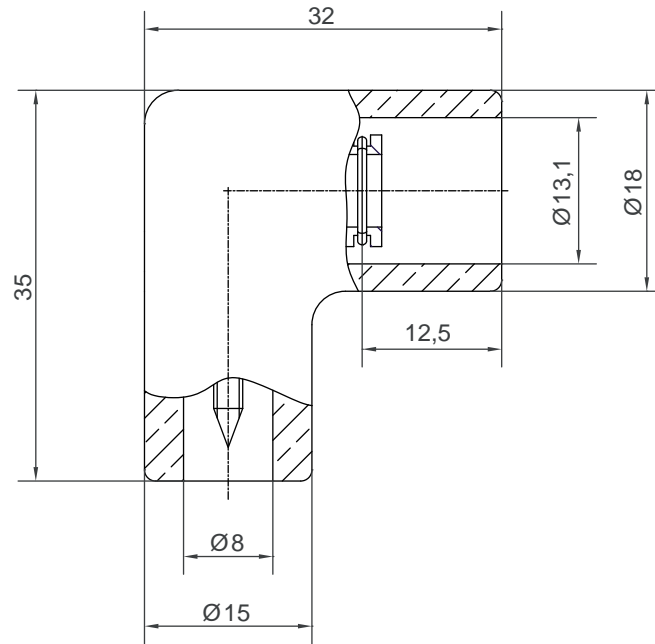

D5001110

**OVERALL DIMENSIONS FOR HV C-5 CONNECTOR**

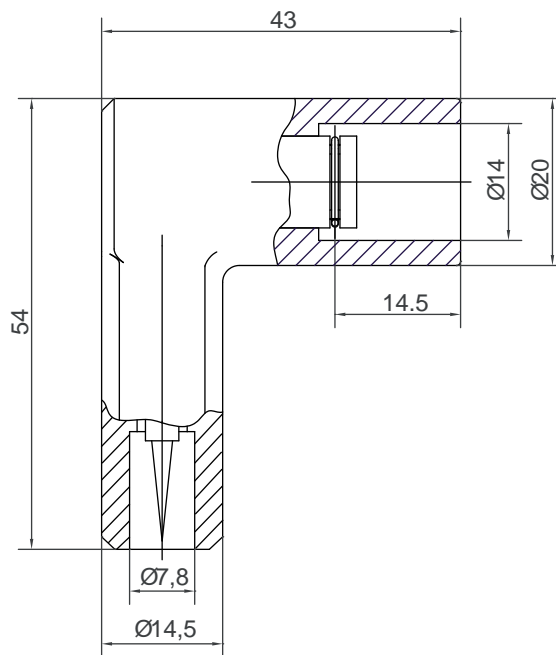

D5001111

**OVERALL DIMENSIONS FOR HV C-6 CONNECTOR**

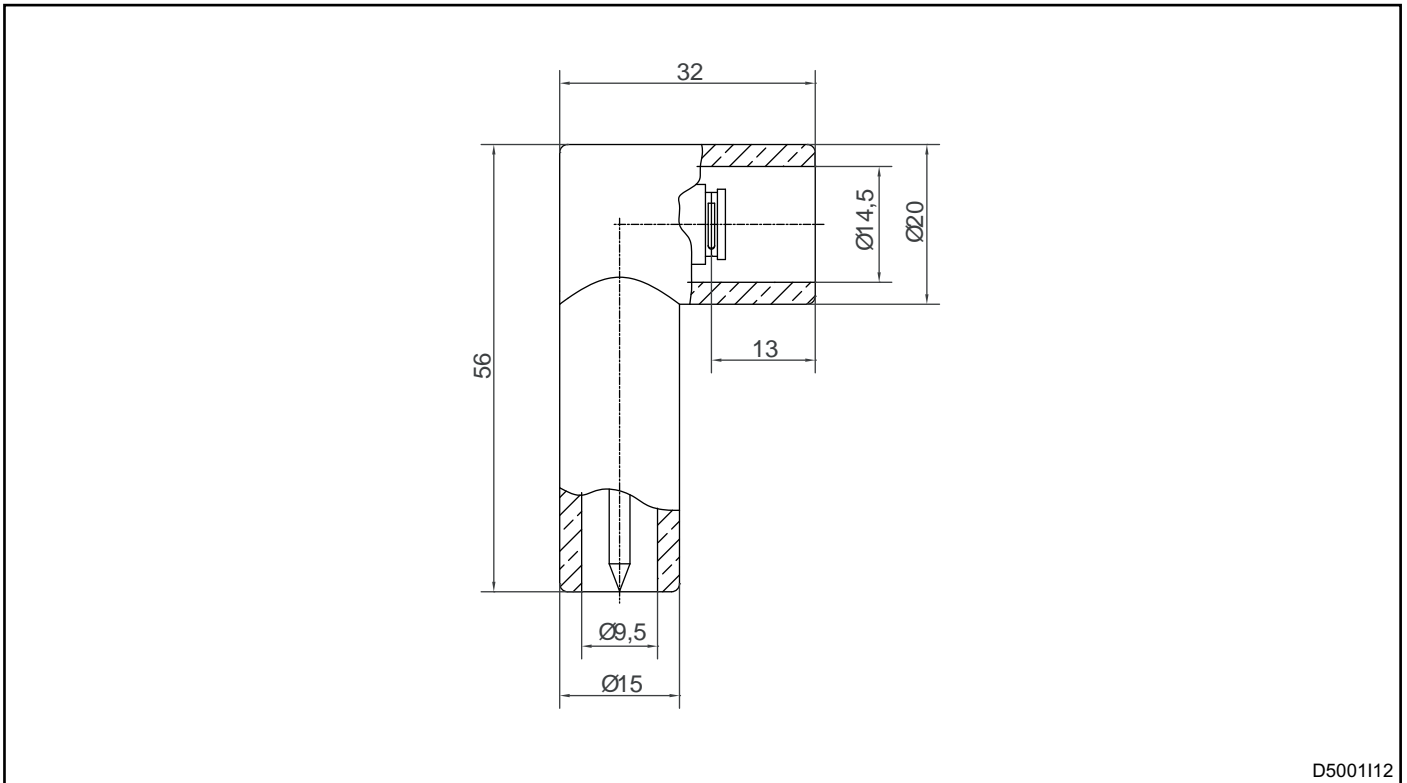

D5001112

**OVERALL DIMENSIONS FOR HV C-7 CONNECTOR**

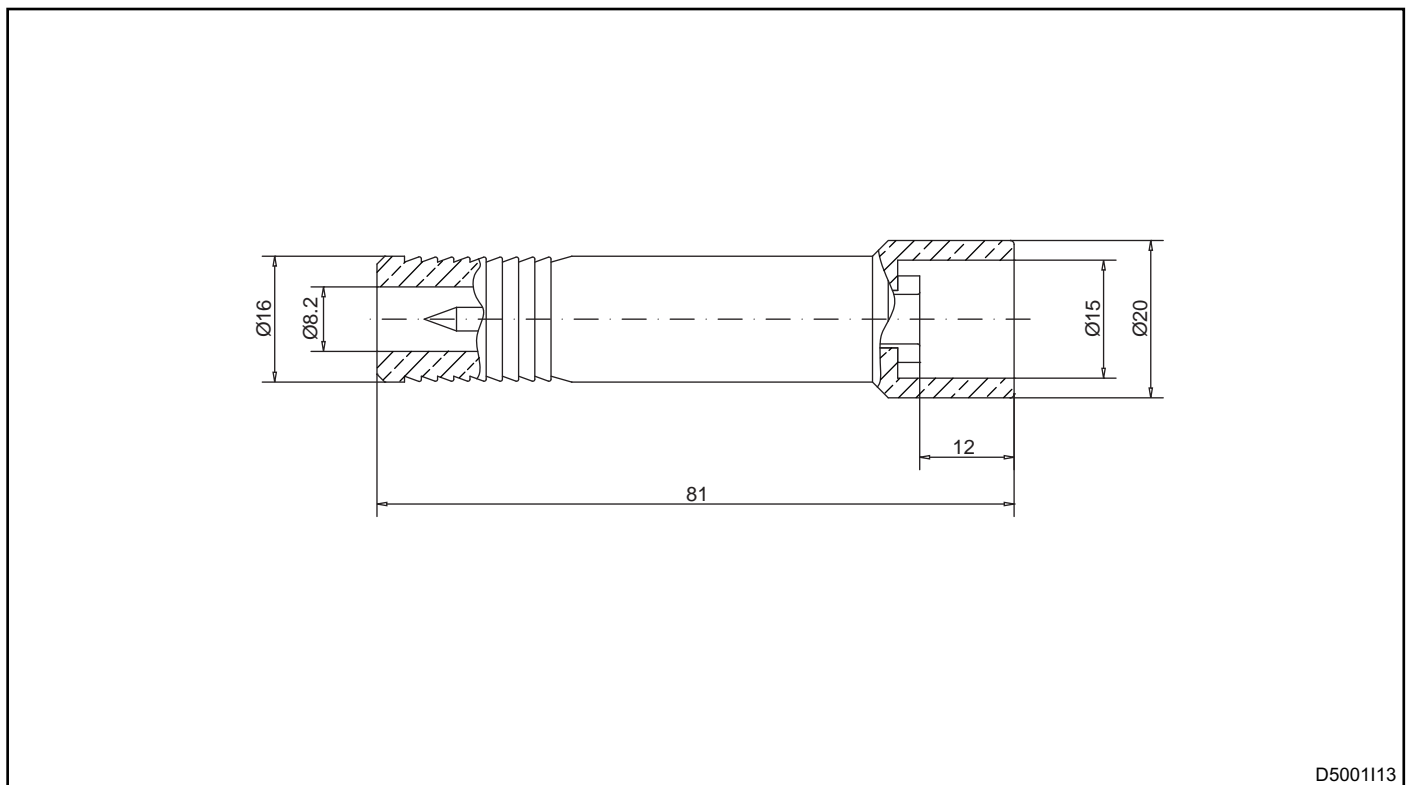

D5001113

**ORDERING CODE - HV CONNECTOR**

HV CONNECTOR -

Model		01
C-2	C-2	
C-5	C-5	
C-6	C-6	
C-7	C-7	

**ORDERING CODE - HV CABLE**

HV CABLE -  -

Model		01
VS	VS	
GVR	GVR	

Quantity		02
length in metres for VS models	...mt	
n. of 50mt hanks for GVR model	...pz	